



PRODUCTS 2019



PARQUET INTELLIGENCE

OUR KNOWLEDGE.
YOUR BENEFITS.

A MATTER OF TRUST

Our family has been connected to the natural element, wood, for more than 180 years. After all, our home town Weiz is located in the middle of green Styria, the province in Austria with the largest abundance of forests. Just as our forests keep on growing, we also undergo continual development and growth. Dr. Nicola Weitzer and Mag. Alexandra Decker-Weitzer, who head the family enterprise, are the seventh generation to run the company, and take great care in continuing the lifework of their parents and grandparents.

“Made in Austria” is a special attribute of our products:

- We perform all work executes by hand in Austria - from cutting the timber, to producing the parquet.
- Social responsibility is an integral part of our corporate policy, which is why we feel very strongly about ensuring that our personnel have jobs in Austria in the future as well.

THIS IS PARQUET INTELLIGENCE:

PERFECT SOLUTIONS FOR ALL AREAS OF USE!

Are you looking for a parquet floor that offers you practical benefits?

Our intelligent solutions: The characteristics of our maintenance-free, healthy, sound-reduction parquet are unique worldwide, and provide extensive evidence of our innovations which set new benchmarks when it comes to parquet flooring, offering convenience, comfort and an enhanced sense of well being!



GENERAL

SURFACES	05
OVERVIEW OF COLOUR RANGES	06
COLOUR RANGES	11
GRADINGS	12
HAPTICS	13
APPEARANCES	14
LAYING PATTERNS	16
MAINTENANCE-FREE PARQUET	18
HEALTHY PARQUET	20
SOUND-REDUCTION PARQUET	22
RENOVATING WITH PARQUET	24

PRODUCTS

iDESIGN PARQUET	
SPECIAL EDITIONS	26
PLANK APPEARANCE	34
WIDEBOARD APPEARANCE	44
BLOCK APPEARANCE	50
STRIP APPEARANCE	55
WOODEN STAIRS WP MULTI	58
PARQUET SKIRTINGS	65
PARQUET ACCESSORIES	68

IMPORTANT INFORMATIONS

WOOD - AT ITS BEST	73
ECOLOGY	76



PARQUET STRUCTURE



2-LAYER PARQUET

A spruce base layer, combined with a real hardwood top layer gives a low floor height construction, which is ideal for renovations



3-LAYER PARQUET

A spruce counterbalance base, combined with a spruce core and a real hardwood top layer gives the highest level of stability - even with floating installation

CONNECTION SYSTEM



TONGUE AND GROOVE

4-side tongue and groove connection



DOUBLE-CLICK

Intelligent, patented double-click system with the greatest interlocking power on the market

WEAR LAYER THICKNESS



APPROX. 2,5 TO 5,0 mm

This refers to the thickness of the hardwood top layer

INSTALLATION TECHNIQUES



COMPLETE ADHESION

Products that are suitable for complete adhesion to subfloor



FLOATING INSTALLATION

Products that are suitable for floating installation on recommended underlays



FLOATING ADHESION

Suitable for the floating adhesion on the underlay WP Looseglue

HYDROSTOP



UNIQUE, ALL-ROUND JOINT-EDGE IMPREGNATION

The Hydrostop impregnation applied at the factory provides the ultimate protection against the ingress of moisture due to small spillages

HERRINGBONE INSTALLATION



LEFT AND RIGHT HAND BLOCKS

Allows for a wide variety of possible installation patterns

WOODEN STAIRS WP MULTI



DON'T FORGET:

there's a stair covering to match every parquet! No matter what wood species, format, colour and additional treatment you use

SUITABLE FOR UNDERFLOOR HEATING*



LIMITED TO VERY GOOD

depending on the relevant layout (level of heating loop), suitable for underfloor heating



SOFT



MEDIUM



STRONG



VERY STRONG

SOFT TO VERY HARD

The hardness of the wood is especially important in terms of pressure points - wear resistance is additionally increased by means of the surface finish

* More about this, beginning on page 74



MAIN-
TENANCE
FREE
PARQUET



SOUND-
REDUCTION
PARQUET

Pre-finished lacquered sealing, consisting of 7 matched eco friendly layers in a satin gloss optical appearance

YOU SEE a satin gloss appearance

YOU FEEL a uniform lacquered finish

INTELLIGENT CHARACTERISTICS

- Maintenance-free for residential living
- Meets Class C of ÖNORM C 2354 (the highest standard for anti-scratch and resistance against certain chemicals, etc.)



PROSTRONG

LACQUERED
SURFACE
FINISH



MAIN-
TENANCE
FREE
PARQUET



SOUND-
REDUCTION
PARQUET

Combines the advantages of the ProStrong surface finish (maintenance-free) with the appearance of the natural Oiled finish Provital

YOU SEE - the natural surface

YOU FEEL the pores

INTELLIGENT CHARACTERISTICS

- Maintenance-free for residential living
- Meets Class C of ÖNORM C 2354 (the highest standard for anti-scratch and resistance against certain chemicals, etc.)



PROACTIVE+

THE NATURAL
MATT SURFACE
FINISH



HEALTHY
PARQUET



SOUND-
REDUCTION
PARQUET

Oil from natural, plant-based raw materials and natural resins, sealing the open pores*

YOU SEE a satiny matt appearance

YOU FEEL the wood structure up close

INTELLIGENT CHARACTERISTICS

- Regular maintenance refreshes the impregnation/protective layer. It is thus ideal for commercial applications.
- Especially breathable. Can be partially renovated.
- Surface oiled at the end of the workshop production execute.

* It is essential that an additional finish be applied to the floor after installation if it is to be used in a public area.



PROVITAL finish

THE NATURAL
OILED SURFACE
FINISH

IMPERIAL PLANK

3-layer Parquet

Dimensions: 3500 x 350 x 18 mm

Dimensions: 3500 x 300 x 18 mm



WP GRAND PLANK

3-layer Parquet

Dimensions: 2400 x 280 x 14 mm

Dimensions: 2400 x 240 x 14 mm

Dimensions: 2400 x 193 x 14 mm



WP CHARISMA PLANK

3-layer Parquet | Dimensions: 2245 x 193 x 14 mm



WP PERFORMANCE PLANK

2-layer Parquet | Dimensions: 1800 x 175 x 9,3 mm



WP COMFORT PLANK

3-layer Parquet | Dimensions: 1800 x 175 x 11 mm



WP QUADRA 1800

3-layer Parquet | Dimensions: 1800 x 175 x 14 mm



WP QUADRA

3-layer Parquet | Dimensions: 1700 x 160 x 14 mm









COLOUR RANGE **LAVA**

COLOUR RANGE **TERRA**

 Oak Krokant

 Oak Krokant

 Fumed Oak Melange
 Fumed Oak

 Oak Cognac
 Oak Coffee
 Oak Havana
 Oak Krokant

 Oak Havana

 Oak Krokant

 Fumed Oak

 Nut steamed

COLOUR RANGE FIRE	COLOUR RANGE NATURE	COLOUR RANGE STONE	COLOUR RANGE SAND
	<ul style="list-style-type: none">  Oak Mandel  Oak  Oak Pure 	<ul style="list-style-type: none">  Oak Auster  Oak Kaschmir  Oak Ice  Oak Savanne  Oak Polar  Oak Trüffelgrau  Oak Taupe 	
	<ul style="list-style-type: none">  Oak Mandel  Oak  Oak Pure 	<ul style="list-style-type: none">  Oak Auster  Oak Kaschmir  Oak Ice  Oak Savanne  Oak Polar  Oak Trüffelgrau  Oak Taupe 	
	<ul style="list-style-type: none">  Oak Mandel  Oak  Oak light  Oak Pure 	<ul style="list-style-type: none">  Oak Auster  Oak Kaschmir  Oak Ice  Oak Savanne  Oak Polar  Oak Trüffelgrau  Oak Colorado Diamond Ice  Oak Taupe 	<ul style="list-style-type: none">  Stone Pine Edelweiss  Ash
	<ul style="list-style-type: none">  Oak 	<ul style="list-style-type: none">  Oak Savanne 	
	<ul style="list-style-type: none">  Oak  Oak Pure 	<ul style="list-style-type: none">  Oak Auster  Oak Kaschmir  Oak Savanne  Ash Polar  Oak Colorado Diamond Ice 	
	<ul style="list-style-type: none">  Oak Mandel  Oak  Oak Pure 	<ul style="list-style-type: none">  Oak Auster  Oak Kaschmir  Oak Ice  Oak Savanne  Oak Polar  Oak Trüffelgrau  Oak Taupe 	

WIDEBOARD-APPEARANCE

WP 4140
2-layer Parquet | Dimensions: 1400 x 140 x 11 mm



WP 4100
2-layer Parquet | Dimensions: 1000 x 125 x 11 mm



WP CHARISMA 2-STRIP
3-layer Parquet | Dimensions: 2245 x 193 x 14 mm

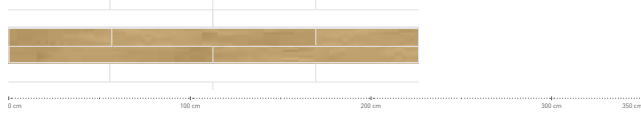

BLOCK-APPEARANCE

WP 450
2-layer Parquet | Dimensions: 500 x 65 x 11 mm



WP CHARISMA 3-STRIP
3-layer Parquet | Dimensions: 2245 x 193 x 14 mm

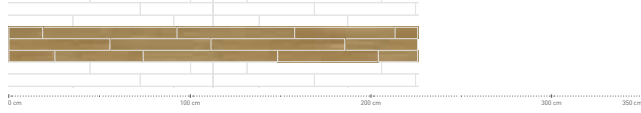

STRIP-APPEARANCE

WP STRIP 45
2-layer Parquet | Dimensions: 360 x 108 x 11 mm



COLOUR RANGE **LAVA**

- Fumed Oak Melange
- Fumed Oak

COLOUR RANGE **TERRA**

- Oak Coffee
- Oak Krokant

- Fumed Oak Melange
- Fumed Oak

- Nut steamed
- Oak Coffee
- Oak Krokant

- Fumed Oak Ice

- Nut steamed

- Fumed Oak

















































- Nut steamed
- Oak Coffee

- Fumed Oak

- Nut steamed
- Oak Havanna

- Fumed Oak

- Nut steamed

COLOUR RANGE FIRE	COLOUR RANGE NATURE	COLOUR RANGE STONE	COLOUR RANGE SAND
	<ul style="list-style-type: none">  Oak Mandel  Oak  Oak Pure 	<ul style="list-style-type: none">  Oak Auster  Oak Kaschmir  Oak Ice  Oak Savanne  Oak Polar  Oak Trüffelgrau  Oak Taupe 	
<ul style="list-style-type: none">  Robinia steamed 	<ul style="list-style-type: none">  Oak Mandel  Oak  Oak Pure 	<ul style="list-style-type: none">  Oak Auster  Oak Kaschmir  Oak Ice  Oak Savanne  Oak Polar  Oak Trüffelgrau  Oak Colorado Diamond Ice  Oak Taupe 	
	<ul style="list-style-type: none">  Oak 	<ul style="list-style-type: none">  Oak Kaschmir  Ash Polar 	
<ul style="list-style-type: none">  Robinia steamed  Beech steamed 	<ul style="list-style-type: none">  Oak 	<ul style="list-style-type: none">  Oak Auster  Oak Kaschmir  Oak Savanne 	<ul style="list-style-type: none">  Ash Latte  Canadian Maple  Ash
<ul style="list-style-type: none">  Robinia steamed  Cherry steamed  Beech steamed 	<ul style="list-style-type: none">  Oak  Oak Pure 	<ul style="list-style-type: none">  Oak Auster  Oak Kaschmir  Oak Savanne  Ash Polar 	<ul style="list-style-type: none">  Canadian Maple  Ash
<ul style="list-style-type: none">  Robinia steamed 	<ul style="list-style-type: none">  Oak 	<ul style="list-style-type: none">  Oak Kaschmir 	<ul style="list-style-type: none">  Ash



MOTHER NATURE GIVES US HER COLOURS

OUR SOURCE OF
INSPIRATION.



LAVA

Colour Range LAVA:
Strong and powerful colour tones. The dark and dusky nuances will produce mysterious and magical shadows and shade, creating an atmosphere of timeless beauty.



TERRA

Colour Range TERRA:
Earthy colour tones - the source of life. Captured in brown hues, these colours will ground your surroundings giving your room warmth and comfort.



FIRE

Colour Range FIRE:
Passionate colours from one end of the red spectrum to the other. These dynamic, bright colours give a feeling of wellbeing and vitality



NATURE

Colour Range Nature:
Refined colour tones. Subtle beautiful shades, neither light nor dark. Understated and restrained, giving a classical finish to your room.



STONE

Our parquet colour range STONE :
A colour range that is full of surprises with its multitude of shades. Varying from cool, light tones, through to the exciting darker versions which will give your rooms a modern and stylish appearance.



SAND

Colour Range SAND:
A glimpse of the seaside. Colour tones that remind you of long sandy beaches the outdoors, and the sound of the sea. These bright hues will bring a feeling of relaxation into your life.

GRADINGS AND HAPTICS

AS VARIED AS LIFE.

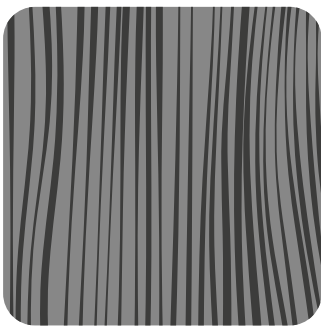

EXQUISITE

The elegant and calm appearance given by grain and colour (with no light-coloured sapwood) satisfies the most exquisite taste.

Characteristics: pin knots, fine grain, no sapwood, rift grain

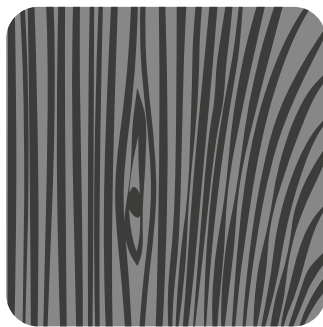

CALM (NATURE AND SELECT)

This grading mixes a timeless grain combination, from simple to decorative.

Characteristics: small knots, natural colour variation, no sapwood



LIVELY (ACCENT, ORIGINAL*)

This grading has a high percentage of sound knots with an even colour variation without sapwood.

Characteristics: knots, natural grain variation no sapwood

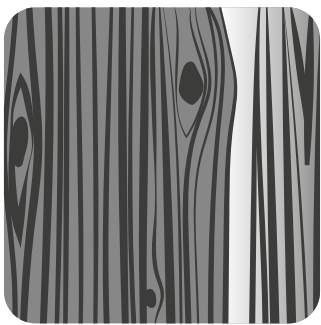

LIVELY COLOURFUL

(NATURAL, ORIGINAL, SPECTRUM, STRUCTURE)

The lively colourful grading offers the whole variety of nature. The large proportion of sapwood produces a harmonious, colourful appearance.

Characteristics: knots, sapwood and natural grain



RUSTIC

(ESSENCE, VIBRANT, ORIGINAL*)

This grade demonstrates the natural growth characteristics of the oak tree.

Characteristics: no limitation on size of knots, open knots, head cracks and variations in colour are permitted, no sapwood



RUSTIC COLOURFUL

(VIBRANT, RUSTIC, ORIGINAL)

The proportion of sapwood produces a colourful appearance with the full expressive power of the tree. Shows character and leaves the tree alive as a piece of living nature.

Characteristics: knots of unlimited size, smoothed-out knots and head cracks, sapwood with natural grain variation, distinct variation in colour and timber structure



BEVELLED

accentuates the plank appearance
adding depth and presence



BRUSHED

emphasizes the natural structure
of the wood grain



DEEP BRUSHED

Emphasizes the wood structure
intensely



INTENSELY BRUSHED

hand-crafted features

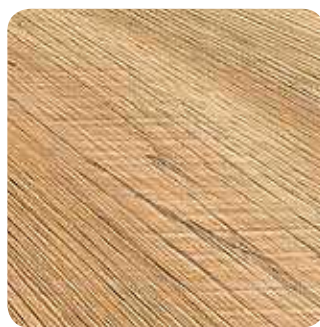

SCRAPED

soft, varied planing imparts a special look
and feel



WEITZER PARKETT APPEARANCES

FOR EVERY STYLE,
WE OFFER THE RIGHT
FORMAT.

PLANK APPEARANCE

- Expressive wood effect which is close-to-nature and works well in large spaces
- Elegant, lively and timeless
- The characteristics of the wood are completely retained, ensuring every floor is unique
- Also available as Grand Plank, which performs a strong appearance with its length and three widths



WIDEBOARD- APPEARANCE

- Generous format between plank and block appearance
- Expression of contemporary design
- Especially well-suited to large, commercial or residential areas
- Also fits stylishly into smaller rooms
- The classic herringbone and French herringbone laying patterns are also possible



BLOCK APPEARANCE

- Timeless, classic format
- Harmonizes with any furniture style
- Offers the greatest freedom of choice of installation patterns, such as herringbone, plait, shifted dice and lamella
- Also perfect for combining with other products



STRIP APPEARANCE

- Unique design from Weitzer Parkett
- Multi-faceted strip appearance in contemporary design
- Gives the room a lively look and a personal touch
- Extraordinarily effective, especially when installed on stairs (waterfall appearance)



LAYING PATTERNS

AT A GLANCE

PLANK APPEARANCE

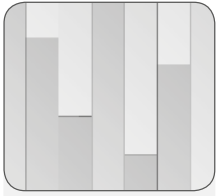

STRAIGHT

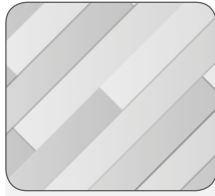

DIAGONAL

WIDEBOARD APPEARANCE

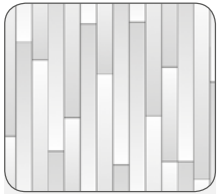

STRAIGHT

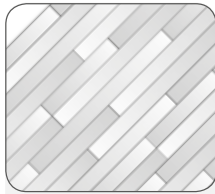

DIAGONAL



LADDER-TYPE*

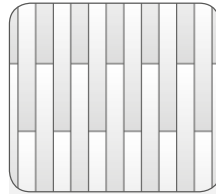

LAMELLA PATTERN **

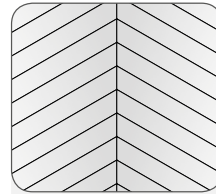

FRENCH HERRINGBONE (60°) **

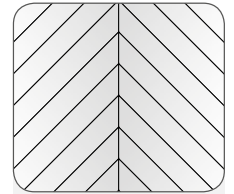

FRENCH HERRINGBONE (45°) **

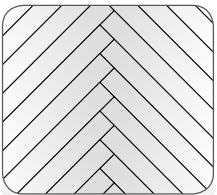

HERRINGBONE **

BLOCK APPEARANCE

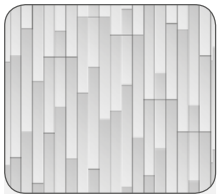

SHIPDECK STRAIGHT



SHIPDECK DIAGONAL

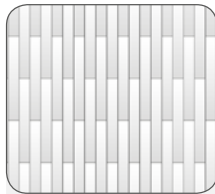

LAMELLA PATTERN **

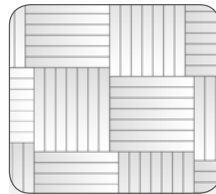

SHIFTED DICE **

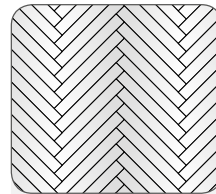

HERRINGBONE **



TWIN-HERRINGBONE **

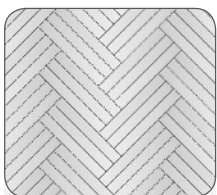

TRIPLE PLAIT **



QUADRUPLE PLAIT **



DIAGONAL LAMELLA **

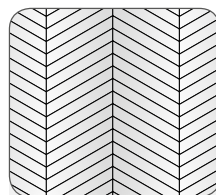

FRENCH HERRINGBONE (60°) **

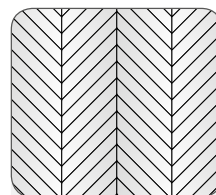

FRENCH HERRINGBONE (45°) **

* Pattern possible with WP 4140 and WP 4100

** Pattern possible with WP 4140, WP 4100 and WP 450

Applies to French Herringbone: All items suitable, except bevelled products with the ProStrong and ProActive + surfaces.

STRIP APPEARANCE

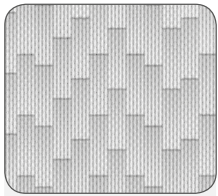

NATURAL LAMELLA STRAIGHT

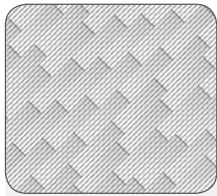

NATURAL DIAGONAL LAMELLA

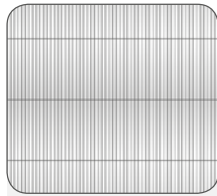

PARALLEL



SHIFTED DICE

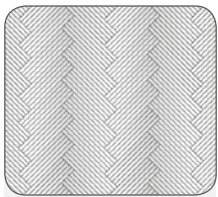

HERRINGBONE

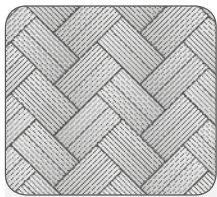

TWIN-HERRINGBONE

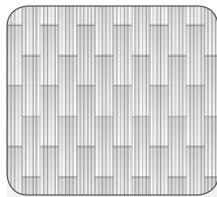

CONTINUOUS LAMELLA PATTERN STRAIGHT

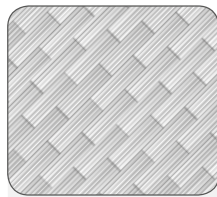

CONTINUOUS LAMELLA PATTERN DIAGONAL

COMBINATIONS

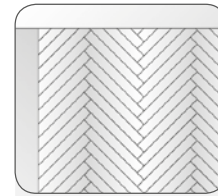

HERRINGBONE WITH BORDER DETAIL ***

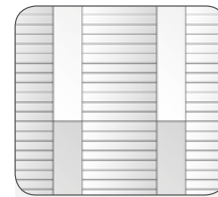

LADDER-TYPE COMBINATION ***

*** Combination: WP 4100 / WP 450

EXAMPLE - HERRINGBONE (BLOCK APPEARANCE)



A timeless classic

No matter if featured in popular house and home magazines or at interior design fairs: **we are breathing fresh life into herringbone floors.**

Achieve different impressive effects using French herringbone laid at 60° or 45°!

Herring-bone and French herringbone are possible in product groups WP 4140, WP 4100, and WP 450! See pages 46, 47, and 52 concerning this.

MAINTENANCE-FREE PARQUET

UNIQUE WORLDWIDE: NO
MAINTENANCE REQUIRED,
SAVES YOU TIME AND MONEY.

REVOLUTIONARY
TECHNOLOGY MEANS ONLY
GENTLE CLEANING IS NEEDED.

I ADORE ACCURATE
APPEARANCES.



SHOWS
DURABILITY.

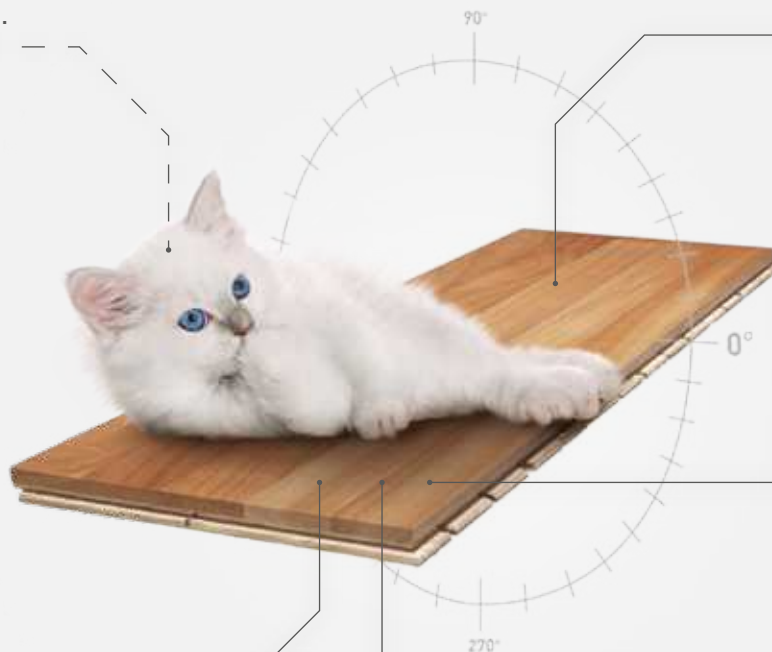

COMPLICATED AND
TIME CONSUMING
MAINTENANCE IS NO
LONGER REQUIRED.

OUR SPECIAL PORE
SEALING PROCESS.

THIS IS PARQUET INTELLIGENCE:

THE WORLD'S FIRST **MAINTENANCE-FREE PARQUET!**

Are you looking for a parquet floor that offers you practical benefits?

Our Intelligent Solution: The unique, special sealing that goes down to the pores, makes our parquet maintenance free. All it takes is a gentle clean saving time and money. Your floor remains beautiful without any maintenance.

WHAT WE UNDERSTAND BY MAINTENANCE-FREE PARQUET

Weitzer Parkett are the first and only manufacturer of this type of parquet flooring. For residential use, the complicated and time consuming maintenance is no longer required. For ProStrong and ProActive+ surfaces, only a light cleaning is required.



MAINTENANCE
FREE

YOU CAN ALWAYS
IDENTIFY OUR
MAINTENANCE-
FREE PRODUCTS
BY THE
MAINTENANCE-
FREE SYMBOL

GUARANTEED BY:

- 7-LAYER UV CURING EXECUTE:

The unique sealing technology of the ProStrong surface, protects the parquet against scratches, abrasion and heavy duty / wear and tear. Multi-layer sealing is also available in a natural matt effect as the ProActive+ surface.

- ONE OF THE LARGEST HARDWOOD-KILN-DRYING FACILITIES IN EUROPE:

Decades of experience in the drying of wood help guarantee greater inherent stability and fitting-accuracy. This helps reduce the appearance of gaps, because the timber has been kiln dried to the level it is expected to achieve in service. ie. EMC - Equilibrium Moisture Content.

- SHOWS DURABILITY.

Our maintenance-free parquet is extremely resistant to scratches and chemicals.



RADIANTLY BEAUTIFUL - DAY IN AND DAY OUT



- SPECIAL WEITZER PARKETT CLEANING PRODUCTS:

Cleaning products that have been specifically developed for Maintenance-free parquet, guarantees long lasting, clean, hygienic and beautiful parquet floors. A small amount of water and the "Clever Cleaner" or, alternatively Cleaning Soap is all that is required. No additional care and maintenance is necessary. Weitzer Parkett cleaning products are ecologically tested and are completely harmless to humans and environmentally friendly

Refer to the Parkett Primer for detailed instructions

- ALL-ROUND PROTECTION WITH JOINT-EDGE IMPREGNATION

- WP Charisma has the finish applied ex-factory
- Reduces water penetration at the header and longitudinal edges
- Increases the resistance of your parquet to liquids and room climate fluctuations on a permanent basis
- Reduces the formation of gaps

HEALTHY PARQUET

FOR A PERFECT
INDOOR CLIMATE.

I LOVE ITS
NATURE.

CREATE HEALTHY
SURROUNDINGS WITH
THE AAAA-EFFECT.

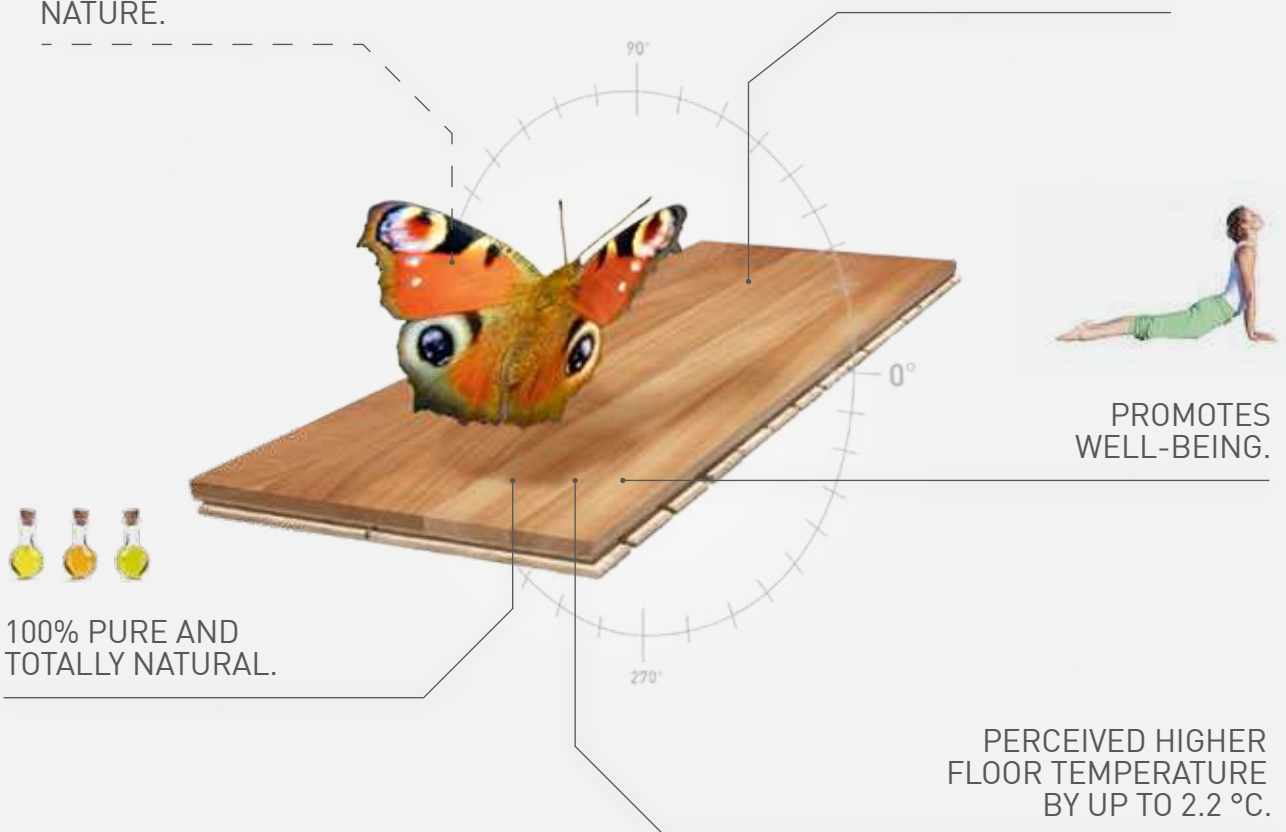

100% PURE AND
TOTALLY NATURAL.

PROMOTES
WELL-BEING.

PERCEIVED HIGHER
FLOOR TEMPERATURE
BY UP TO 2.2 °C.

THIS IS PARQUET INTELLIGENCE:

THE FIRST **HEALTHY PARQUET** WITH AAAA-EFFECT!

Are you looking for a parquet floor that offers you healthy surroundings?

Our Intelligent Solution: our healthy parquet with its allergy-free, antibacterial, antistatic and alive qualities, creates a hygienic, healthy atmosphere of well-being. Contrary to carpets, dust and dirt cannot get a permanent foothold on the smooth surfaces and mites have no habitat. With its special surfaces, you feel the wood structure very close: intensely brushed or scraped.

WHAT WE UNDERSTAND BY HEALTHY PARQUET

This type of floor covering has a significant influence on individuals. Weitzer Parkett have created Healthy Parquet specifically to provide and promote a healthy climate and wellbeing.



HEALTHY

YOU CAN
ALWAYS
IDENTIFY
OUR HEALTHY
PRODUCTS BY
THE HEALTHY
SYMBOL

THE UNIQUE ADVANTAGES:

- 100% PURE - NATURAL OILS AND WAXES FROM RENEWABLE RESOURCES

The surface of the healthy parquet is treated only with natural oils and waxes that penetrate deep into the pores and provide the parquet with strong protection. This extremely breathable surface creates a sense of well being and healthy living that helps restrict / reduce / remove allergens from the environment of the potential allergy sufferer. When it comes to appearance, our healthy parquet boasts a natural timber structure that really stands out thanks to the oiled surface.

- THE NATURAL MATERIAL WOOD

Wood brings comfort and warmth into the room. The latest studies of an independent German test institute prove: Increase in surface temperature for parquet compared to

- laminate by up to 0.8°C
- tiles by up to 2.2°C

This helps save heating costs!

- ROOM CLIMATE REGULATION

Wood in a room promotes regulation of the humidity and the optimum conditions are 50% humidity and 20°C room temperature. The more wood within a room, the better the climate can be controlled, health problems triggered by too dry or humid air are minimized.

- THE AAAA -EFFECT

Allergy-sufferer friendly | **Antibacterial** | **Antistatic** | **Alive**

The perfect surfaces, By it's allergy-free antibacterial, antistatic and alive qualities, Weitzer Parkett creates a hygienic, healthy atmosphere of well-being. Contrary to carpets, dust and dirt cannot get a permanent foothold on the smooth surfaces and mites have no habitat.

PARQUET CARE!



- PARQUET FOR A LIFE TIME

When it comes to wooden floors, a distinction is made between cleaning and care. Ongoing cleaning ensures a clean surface day in and day out. Parquet care protects the wood and gives protection. Regular care ensures that the surface retains its original finish.

Refer to the instruction to parquet brochure for more information.

SOUND-REDUCTION PARQUET

COMPACTNESS IN IT'S
QUIETEST, MOST
BEAUTIFUL FORM.

DRASTIC
NOISE-
REDUCTION!

I LOVE THE PEACE
AND QUIET.

FORMS PERFECT
BOND TO THE
SUBSTRATE.

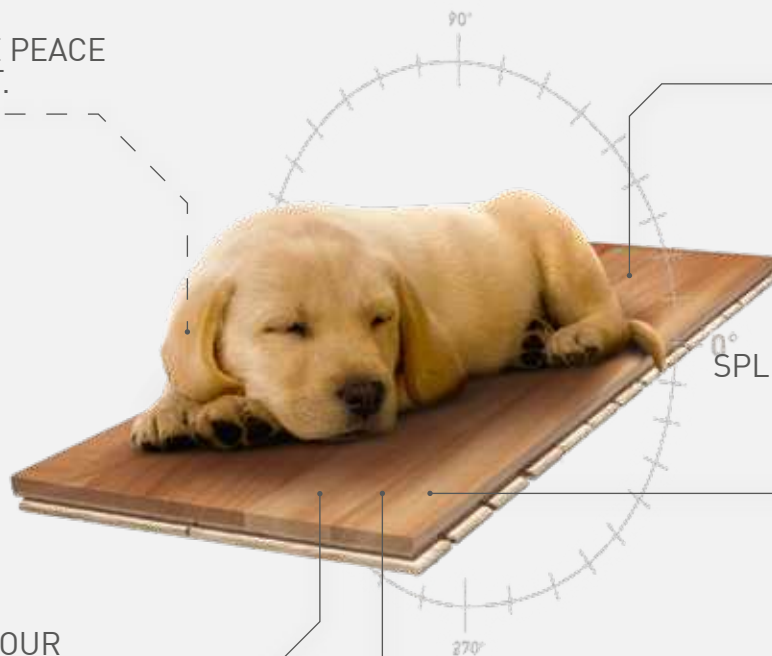

SPLENDID ROOM ACOUSTICS VIA
PLEASANT
FREQUENCY RANGE.

ENHANCES YOUR
WELL-BEING.

ADDITIONAL NOISE REDUCTION IN
CONJUNCTION WITH WP LOOSEGLUE

THIS IS PARQUET INTELLIGENCE:

SOUND-REDUCTION PARQUET -
ENSURES PERFECT ROOM ACOUSTICS



Do you long for peace and quiet?

Our Intelligent Solution: The firm bond between parquet and substrate engenders compactness. According to independent German testing, our bonded whisper parquet is up to three times quieter than laminate. Added to this is the beneficial frequency range of the raw material, wood — not for nothing are concert halls and instruments often made of it.

WHAT WE UNDERSTAND BY SOUND-REDUCTION PARQUET

Room acoustics play a vital role in personal well-being. Weitzer Parkett specializes in this field and the Sound-reduction parquet helps to create an atmosphere of relaxation.

– THE NATURAL MATERIAL WOOD

In contrast to other floor coverings, parquet guarantees a comfortable frequency range. There are good reasons why concert halls and musical instruments are manufactured from wood.

– PERMANENT BOND

Complete surface bonding by professionals, provides perfect contact with the underlay, thereby minimising distribution of ambient sound.

– THE PROVITAL-SURFACE

Our Sound-reduction parquet achieves an outstanding reduction of ambience noise due the printive surface texture of the timbers used.

– WP LOOSEGLUE AND SOUND-REDUCTION PARQUET: A DREAMTEAM!

Thanks to the outstanding noise-reduction abilities of the WP Looseglue underlay one can achieve a reduction of subsonic noise by 18dB and a significant reduction of ambient noise at the same time. The result is the splendidly deep, compact sound of your footsteps. You combine the advantages of the two installation techniques — floating installation and the adhesion of the parquet — killing two birds with one stone; it's a completely dust-free renovation and an improvement in room acoustics. The result is the splendidly deep, compact sound of your footsteps.

OUR SOUND-REDUCTION SOLUTIONS:

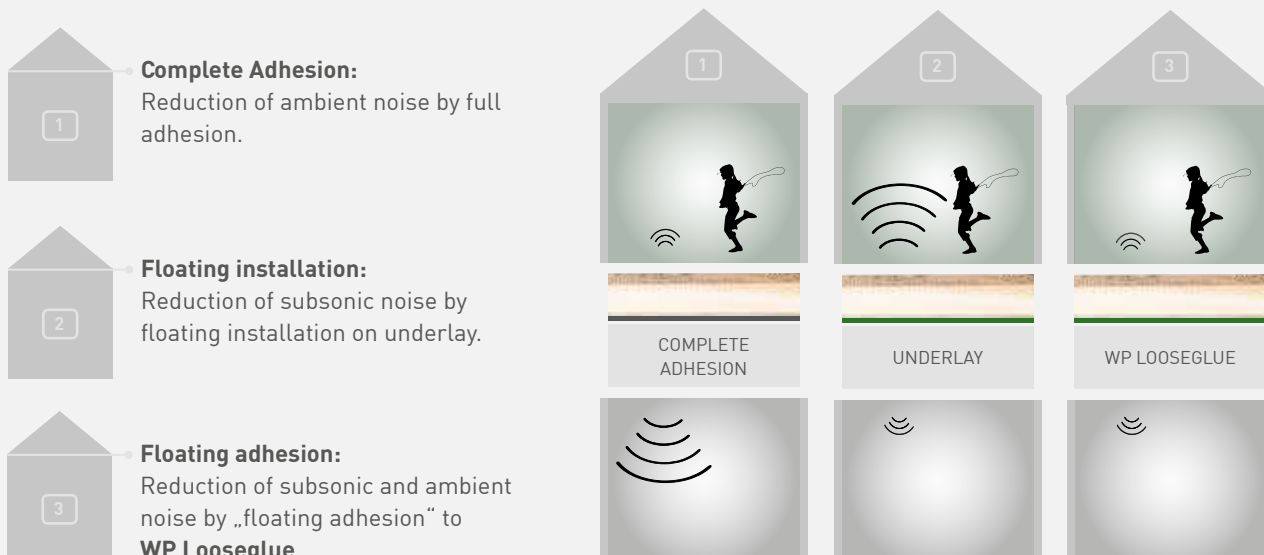

RENOVATING WITH WEITZER PARKETT

SO FAST.
SO DUST-FREE.
SO QUIET.

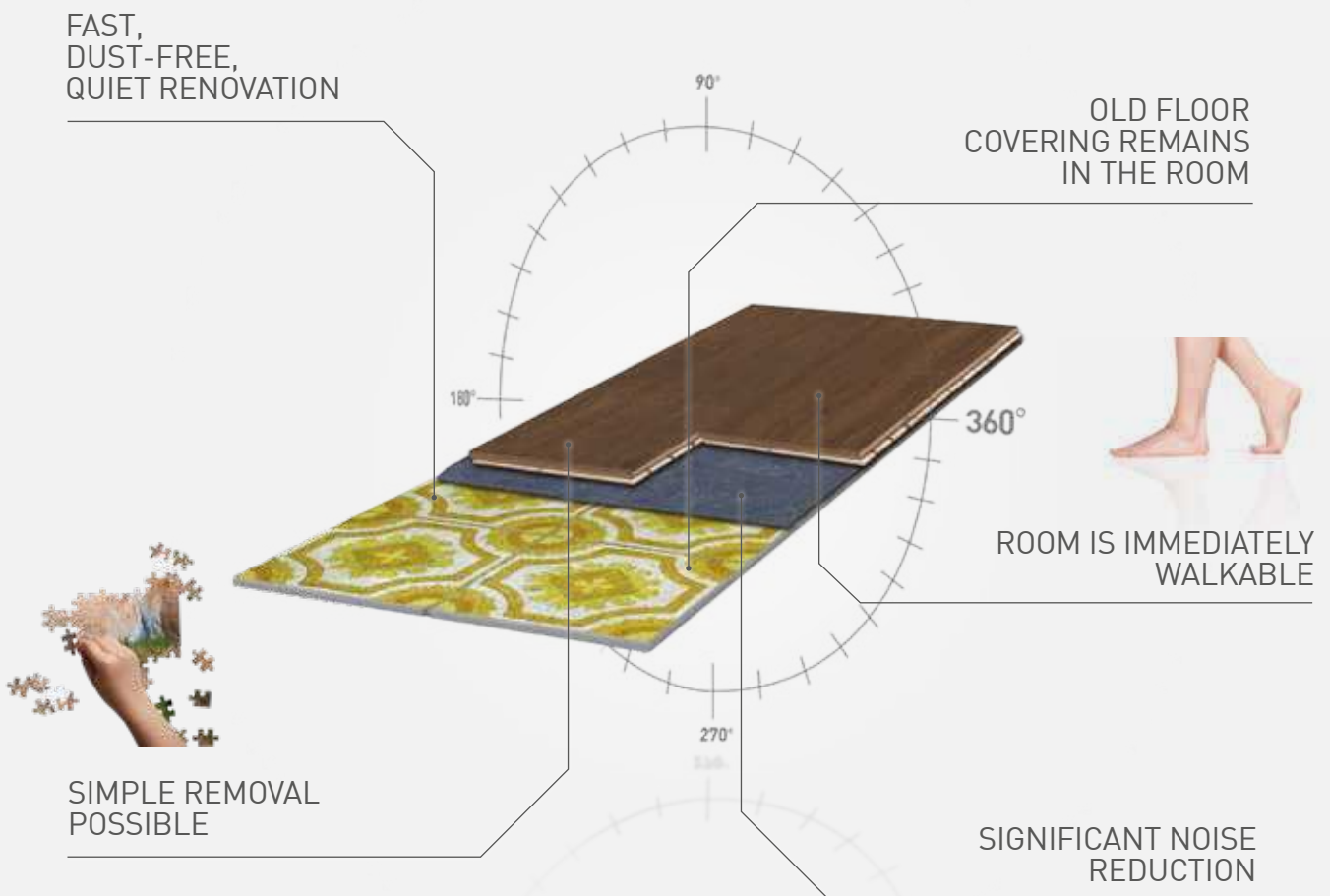

THIS IS PARKETT INTELLIGENCE:

RENOVATION HAS NEVER BEEN **SO FAST,**
SO DUST-FREE AND QUIET.

Would you like your floor to be renovated quickly, without dust, and as quietly as possible?

Our intelligent solution: With the system solution from Weitzer Parkett, you renovate your floor within a few hours. The old floor covering can remain in the room. The new parquet floor is immediately walkable. No dust and no noise in order to tear out the old floor. The system simultaneously combines all of the advantages of professional adhesion and floating installation! You achieve the greatest noise reduction and hear only the splendidly deep, compact sound of your footsteps.

WHAT WE MEAN BY RENOVATION

One generally ponders the renovation of a floor covering for a long time. One fears the effort and costs. However with Weitzer Parkett, that more often means renovation WITHOUT dust, WITHOUT noise, and WITHOUT boring tasks.

Weitzer Parkett has developed an overall solution that enables dust-free renovation. One achieves perfect room acoustics as well.



ADHESION
FLOATING

YOU
RECOGNIZE
PRODUCTS
THAT CAN BE
INSTALLED
WITH WP
LOOSEGLUE
BY THIS IN-
STALLATION
SYMBOL.

THE UNIQUE BENEFITS:

– FAST, DUST-FREE, QUIET RENOVATION

With the renovation solution from Weitzer Parkett, you work quickly, without dust, and quietly! The simplest installation technique guarantees a customer- AND craftsmanship-friendly solution.

– THE OLD FLOOR COVERING STAYS IN THE ROOM

Your new parquet is installed over the old floor covering. The unique WP Looseglue matting finds space between them. The difference to traditional underlay mats for floating installation consists in adhesion to the parquet so that even most 2- and 3- layer products can be installed. A level difference can be avoided in most cases in combination with parquet having a less thickness. The parquet is immediately walkable again after installation.

– FAST, SIMPLE INSTALLATION

The most important adjustments to the renovation work, for example to door linings and skewed masonry, are now quite simple. Adjust until the element sits perfectly then pull off the WP Looseglue's cover film and done! Entirely without adhesive! Tongue-and-groove products are especially well suited for this.

– THE ROOM IS IMMEDIATELY WALKABLE

Movable furniture can also stay in the room — you push it to one side of the room and install on the other. Then repeat the same procedure with the other half of the room. The room can be traversed again immediately thanks to the system solution with intelligent installation technique.

– PERFECT ROOM ACOUSTICS

Thanks to the outstanding noise-reduction abilities of the WP Looseglue underlay one can achieve a reduction of subsonic noise by 18dB and a significant reduction of ambient noise at the same time. The result is the splendidly deep, compact sound of your footsteps. You combine the advantages of the two installation techniques — floating installation and the adhesion of the parquet — killing two birds with one stone; it's a completely dust-free renovation and an improvement in room acoustics.

– SIMPLE REMOVAL POSSIBLE

WP Looseglue is also ideal for preserving the subfloor regardless of whether it's a floor worthy of historical preservation or a simple lettable area that is destined to be returned to its original condition after use. Easy removal also offers an uncomplicated renovation solution if the wish for a new parquet floor exists years later.

iDESIGN PARQUET[®] SPECIAL EDITION

CONFIGURED ACCORDING
TO YOUR TASTE BY
WEITZER PARKETT



WEITZERART: TWINART

THE PRECIOUS ARTWORK OF TREES.

TECHNICAL DATA:

- Imperial Plank | Oak & Fumed Oak
- Tongue and groove joint on four sides **(01)**
- The plank appearance is emphasized thanks to bevel of the longitudinal and header joints **(02)**
- Spruce supporting material with vertically arranged growth rings **(03)**
- Suitable for underfloor heating **(04)**
- We recommend complete adhesion to subfloor

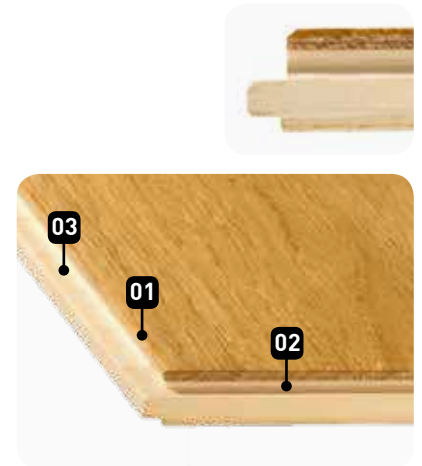

DIMENSIONS:
2245 x 350 x 16,6 mm
Overall thickness 16,6 mm with
3 mm wear layer

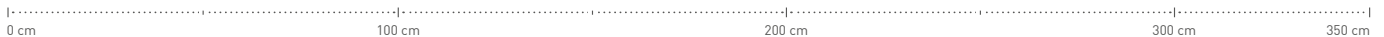

PLANK APPEARANCE | 3-LAYER PARQUET



3,6



PLANK APPEARANCE | WP TWINART | FUMED OAK | BEVELLED

TWIST PARQUET

YOUR PATTERN. MY PATTERN.
INSTALL ME ANY WAY YOU WANT.

THE NEW PANEL APPEARANCE WITH MUCH MORE ROOM FOR CREATIVITY!

Twist parquet finally gives the room the individuality it deserves!
Weitzer Parkett combines the most important trends from haptics, colour and size in a unique item.



TECHNICAL DATA:

- One longitudinal tongue —3-sided groove plus false tongue for the front side **(01)**
- Spruce supporting material with vertically arranged growth rings **(02)**
- With bevel **(03)** or trendy Soft Line **(04)** on request[†]

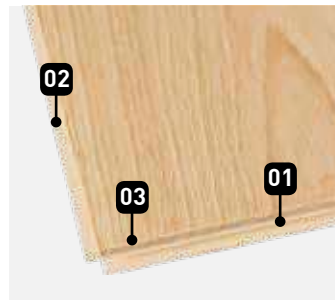

4 FORMATS

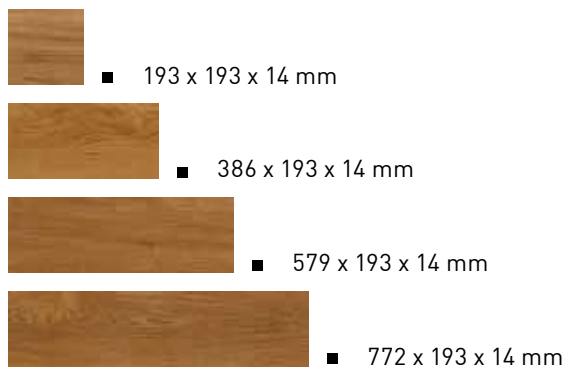

Total thickness for all four formats is 14 mm with about 3.6 mm top layer.

0 cm 100 cm

2 PRODUCT LINES

- OAK ICE | RUSTIC (ESSENCE) BEVELLED, STONEWASHED
powerful white tones combined with a distinct brushing
- OAK | CALM (SELECT) | SOFTLINE
a soft, rounded bevel enhances the formats

DIMENSIONS: WP TWIST MIX

UNIT	PACKAGE	PALLET	ASSORTMENT PER PACKAGE: 4x: 193 x 193 x 14 mm 3x: 386 x 193 x 14 mm 2x: 579 x 193 x 14 mm 2x: 772 x 193 x 14 mm
CONTENTS	11 boards = 0,89 m ²	72 packages = 64,08 m ²	
DIMENSIONS	0,77 x 0,19 x 0,08 m	1,20 x 0,80 x 1,16 m	
WEIGHT	approx. 6,60 kg	approx. 475,20 kg	

PANEL APPEARANCE | 3-LAYER PARQUET



POSSIBLE LAYING PATTERNS—THE CHOICES ARE:

- **WP Twist MIX:** all four formats invite you to design and play - entirely individual and creative patterns emerge
- **WP Twist 772** > Completely en vogue - contemporary and generously interpreted:
- **WP Twist 579** > the traditional herringbone pattern in our exciting panel-appearance format.

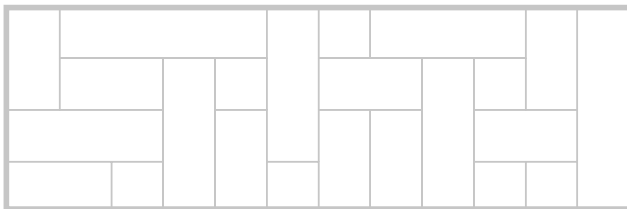

- MIX pattern: an example of innumerable installation possibilities

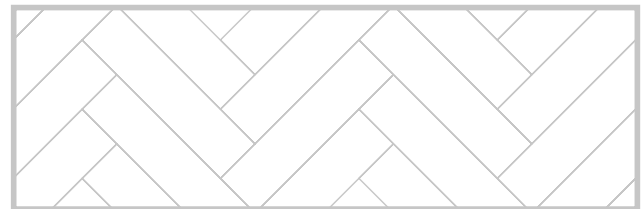

- Herringbone pattern

DIMENSIONS: WP TWIST 772 (772 x 193 x 14 mm)

UNIT	PACKAGE	PALLET
CONTENTS	6 boards = 0,89 m ²	72 packages = 64,08 m ²
DIMENSIONS	0,77 x 0,19 x 0,08 m	1,20 x 0,80 x 1,16 m
WEIGHT	approx. 7,10 kg	approx. 511,20 kg

DIMENSIONS: WP TWIST 579 (579 x 193 x 14 mm)

UNIT	PACKAGE	PALLET
CONTENTS	6 boards = 0,67 m ²	96 packages = 64,32 m ²
DIMENSIONS	0,58 x 0,19 x 0,08 m	1,20 x 0,80 x 1,16 m
WEIGHT	approx. 5,20 kg	approx. 499,20 kg



OAK ALPINE SUN

MY COLOUR IS LIKE
THE GENTLE TOUCH OF THE SUN.

TECHNICAL DATA:

- WP Charisma Plank | Oak Alpine sun
- Intelligent patented double-click system with the greatest interlocking power on the market. **(01)**
- Patented press-stud principle for simultaneous locking of the longitudinal and header joints in one movement **(02)**:
 - Fast and simple one-man assembly and disassembly
 - Can be completely adhered to the subfloor*
- Header joint edge locking mechanism made from solid hardwood only - completely free from plastic components and plasticizers **(03)**
- Spruce supporting material with vertically arranged growth rings **(04)**

* Ideally suited to underfloor heating, as it can be completely adhered to the subfloor

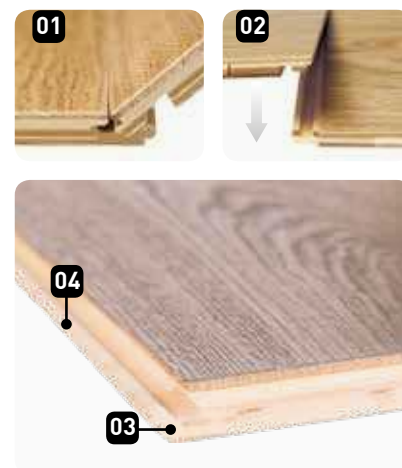

DIMENSIONS:
2245 x 193 x 14 mm
Overall thickness 14 mm with
3,6 mm wear layer

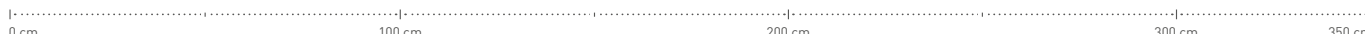

PACKING UNITS

UNIT	PACKAGE	PALLET
CONTENTS	6 boards = 2,60 m ²	35 packages = 91,00 m ²
DIMENSIONS	2,28 x 0,215 x 0,085 m	2,28 x 1,10 x 0,71 m
WEIGHT	approx. 19,80 kg	approx. 693 kg

PLANK APPEARANCE | 3-LAYER PARQUET



PLANK APPEARANCE | OAK ALPINE SUN | RUSTIC (ESSENCE) | BEVELLED, BRUSHED



PLANK APPEARANCE

NATURE'S FINEST.

TRUE LUXURY:
ONLY AROUND 17% OF THE TRUNK
OF A TREE CAN BE USED TO
ACHIEVE THE PLANK APPEARANCE!
THAT MAKES EVERY PIECE A UNIQUE
AND VALUABLE ITEM.



IMPERIAL PLANK

3-LAYER PARQUET



- In two exclusive formats that demonstrate true splendour
- The plank appearance is emphasized thanks to bevelling of the longitudinal and header joints **(01)**
- Tongue and groove joint on four sides **(02)**
- Spruce supporting material with vertically arranged growth rings **(03)**
- Suitable for underfloor heating
- The Imperial plank has to be fully adhered

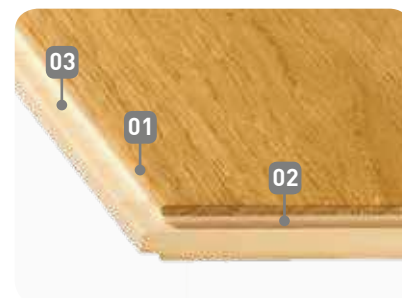

Installing a fidbox® (climate measuring device) is strongly recommended. This enables specialist advice to be sought including indoor climate optimization even after the parquet has been installed. This preserves the value and beauty of the floor and ensures a long life of the same.

DIMENSIONS:

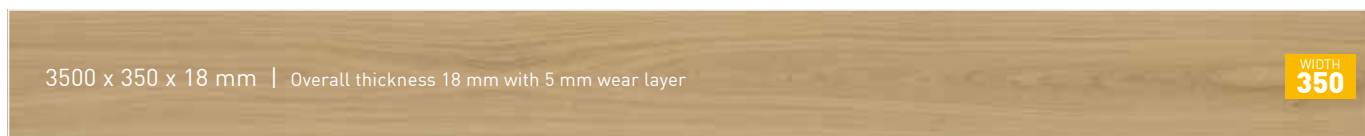

3500 x 350 x 18 mm | Overall thickness 18 mm with 5 mm wear layer

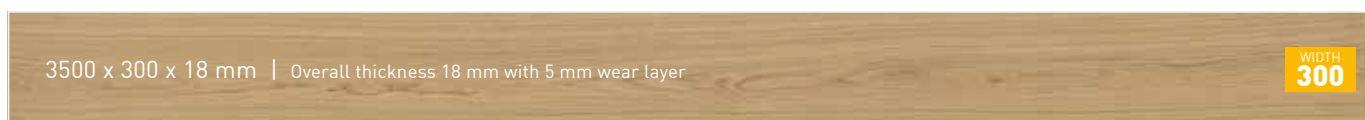

3500 x 300 x 18 mm | Overall thickness 18 mm with 5 mm wear layer

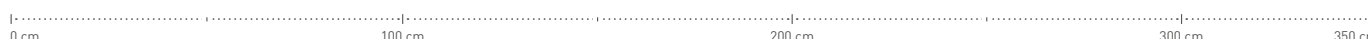

DIMENSIONS: 3500 x 350 x 18 mm

UNIT	PACKAGE	PALLET
CONTENTS	2 boards = 2,45 m ²	45 packages = 100,25 m ²
DIMENSIONS	3,51 x 0,36 x 0,04 m	3,51 x 1,08 x 0,713 m
WEIGHT	approx. 21,8 kg	approx. 981 kg

DIMENSIONS: 3500 x 300 x 18 mm

UNIT	PACKAGE	PALLET
CONTENTS	2 boards = 2,10 m ²	45 packages = 94,5 m ²
DIMENSIONS	3,51 x 0,31 x 0,04 m	3,51 x 0,93 x 0,713 m
WEIGHT	approx. 18,7 kg	approx. 841,5 kg

EDGE PROFILE FOR STEPS: Fixed length: 3,50 m; profile 40, 40 style, 58 style and block style | Profile block style: riser is delivered loose.
FOR ALL DIMENSIONS



WP GRAND PLANK 3-LAYER PARQUET



- The plank appearance is emphasized thanks to bevelling of the longitudinal and header joints **(01)**
- Tongue and groove joints on four sides. Can be completely adhered to the subfloor. Also suitable for floating installation in optimal room climates **(02)**
- Spruce supporting material with vertically arranged growth rings **(03)**
- Ideally suited to underfloor heating, as it can be completely adhered to the subfloor

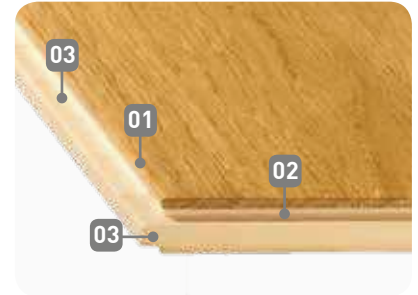

Installing a fidbox® (climate measuring device) is strongly recommended. This enables specialist advice to be sought including indoor climate optimization even after the parquet has been installed. This preserves the value and beauty of the floor and ensures a long life of the same.

DIMENSIONS:

2400 x 280 x 14 mm Overall thickness 14 mm with 3,6 mm wear layer	WIDTH 280
2400 x 240 x 14 mm Overall thickness 14 mm with 3,6 mm wear layer	WIDTH 240
2400 x 193 x 14 mm Overall thickness 14 mm with 3,6 mm wear layer	WIDTH 193

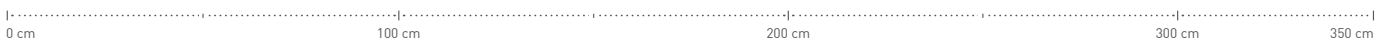

DIMENSIONS: 2400 x 280 x 14 mm

UNIT	PACKAGE	PALLET
CONTENTS	6 boards = 4,03 m ²	24 packages = 96,77 m ²
DIMENSIONS	2,41 x 0,29 x 0,08 m	2,41 x 1,17 x 0,612 m
WEIGHT	approx. 26,62 kg	approx. 649 kg

DIMENSIONS: 2400 x 240 x 14 mm

UNIT	PACKAGE	PALLET
CONTENTS	6 boards = 3,46 m ²	24 packages = 82,94 m ²
DIMENSIONS	2,41 x 0,25 x 0,08 m	2,41 x 1,01 x 0,612 m
WEIGHT	approx. 25,98 kg	approx. 633,7 kg

DIMENSIONS: 2400 x 193 x 14 mm

UNIT	PACKAGE	PALLET
CONTENTS	6 boards = 2,78 m ²	30 packages = 83,38 m ²
DIMENSIONS	2,41 x 0,20 x 0,08 m	2,41 x 1,03 x 0,612 m
WEIGHT	approx. 22,75 kg	approx. 692,5 kg

EDGE PROFILE FOR STEPS: Fixed length: 2,40 m; profile 40, 40 style, 58 style and block style | Profile block style: riser is delivered loose.
FOR ALL DIMENSIONS



WP CHARISMA PLANK
3-LAYER PARQUET



- Intelligent patented double-click system with the greatest interlocking power on the market. **(01)**
- Patented press-stud principle for simultaneous locking of the longitudinal and header joints in one movement **(02)**:
 - Fast and simple one-man assembly and disassembly
 - Can be completely adhered to the subfloor*
- Header joint edge locking mechanism made from solid hardwood only - completely free from plastic components and plasticizers **(03)**
- Spruce supporting material with vertically arranged growth rings **(04)**
- HydroStop:
 - Unique all-round joint-edge impregnation
 - Provides the ultimate protection against the ingress of moisture due to small spillages
- Ideally suited to underfloor heating, as it can be completely adhered to the subfloor
- **NOW NEW:** The WP rotatable plank allows a simple modification of the laying direction

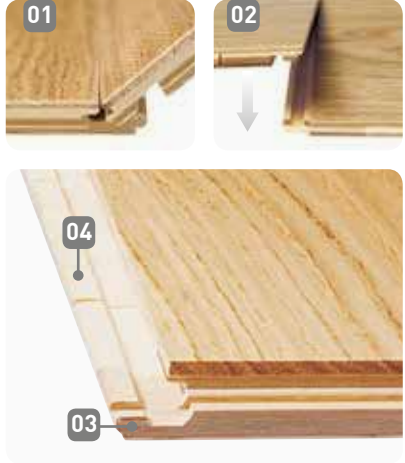

DIMENSIONS:
2245 x 193 x 14 mm
Overall thickness 14 mm with
3,6 mm wear layer

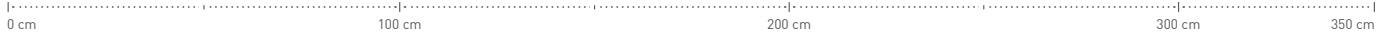

PACKING UNITS

UNIT	PACKAGE	PALLET
CONTENTS	6 boards = 2,60 m ²	35 packages = 91,00 m ²
DIMENSIONS	2,28 x 0,215 x 0,085 m	2,28 x 1,10 x 0,71 m
WEIGHT	approx. 19,80 kg	approx. 693 kg
EDGE PROFILE FOR STEPS	Fixed length: 2,245 m; profile 40, 40 style, 58 style and block style. Block style: riser is delivered loose.	



WP PERFORMANCE PLANK

2-LAYER PARQUET



- Low construction height : 9,3 mm
- For smooth transitions between rooms and different flooring materials
- Perfectly suited for renovation due to the low structural height
- The plank appearance is emphasized thanks to bevel of the longitudinal and header joints **(01)**
- Tongue and groove joint on four sides, optimally suited for complete surface bonding **(02)**
- Supporting material made from moisture resistant HDF **(03)**
- Ideally suited to underfloor heating



DIMENSIONS:
 1800 x 175 x 9,3 mm
 Overall thickness 9,3 mm with
 2,5 mm wear layer



PACKING UNITS

UNIT	PACKAGE	PALLET
CONTENTS	8 boards = 2,52 m ²	36 packages = 90,72 m ²
DIMENSIONS	1,820 x 0,190 x 0,074 m	1,822 x 1,182 x 0,456 m
WEIGHT	approx. 20 kg	approx. 730 kg
EDGE PROFILE FOR STEPS	Fixed length: 1,80 m; profile 40, 40 style, 58 style and block style; Block style: riser is delivered loose.	

WP COMFORT PLANK

3-LAYER PARQUET

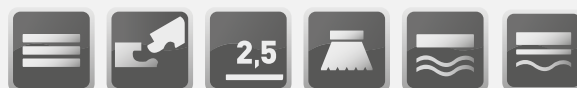

- Intelligent patented double-click system with the greatest interlocking power on the market. **(01)**
- Patented press-stud principle for simultaneous locking of the longitudinal and header joints in one movement **(02)**:
 - Fast and simple one-man assembly and disassembly
 - Can be completely adhered to the subfloor
- Header joint edge locking mechanism made from spruce wood only - completely free from plastic components and plasticizers **(03)**
- Spruce supporting material with vertically arranged growth rings **(04)**
- **NOW NEW:** The WP rotatable plank allows a simple modification of the laying direction



DIMENSIONS:
1800 x 175 x 11 mm
Overall thickness 11 mm with
2,5 mm wear layer



PACKING UNITS

UNIT	PACKAGE	PALLET
CONTENTS	8 boards = 2,52 m ²	42 packages = 105,84 m ²
DIMENSIONS	1,8 x 0,175 x 0,011 m	1,82 x 1,2 x 0,74 m
WEIGHT	approx. 14,85 kg	approx. 623,7 kg
EDGE PROFILE FOR STEPS	Fixed length: 1,80 m; profile 40, 40 style, 58 style and block style. Block style: riser is delivered loose.	

WP QUADRA 1800 | WP QUADRA 3-LAYER PARQUET



- The plank appearance is emphasized thanks to bevelling of the longitudinal and header joints **(01)**
- Tongue and groove joints on four sides. Can be completely adhered to the subfloor. Also suitable for floating installation in optimal room climates **(02)**
- Spruce supporting material with vertically arranged growth rings **(03)**
- Suitable for underfloor heating; optimal with full-surface adhesion

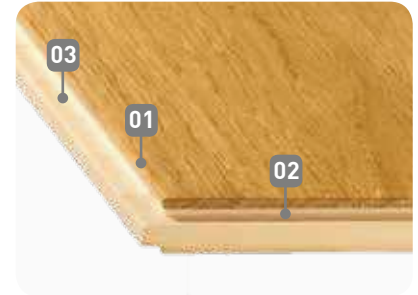

DIMENSIONS WP QUADRA 1800:
1800 x 175 x 14 mm
Overall thickness 14 mm with 3,6 mm wear layer

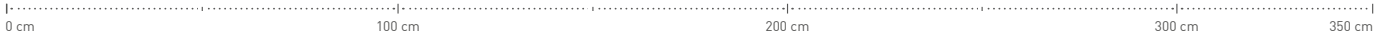

DIMENSIONS WP QUADRA:
1700 x 160 x 14 mm
Overall thickness 14 mm with 3,6 mm wear layer

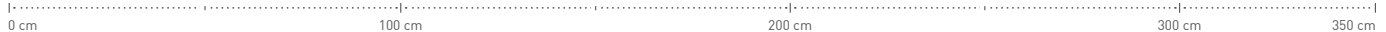

PACKING UNITS | WP QUADRA 1800

























UNIT	PACKAGE	PALLET
CONTENTS	6 boards = 1,89 m ²	60 packages = 113,40 m ²
DIMENSIONS	1,81 x 0,19 x 0,09 m	1,85 x 1,14 x 0,95 m
WEIGHT	approx. 12,35 kg	approx. 807 kg
EDGE PROFILE FOR STEPS	Fixed length: 1,80 m; profile 40, 40 style, 58 style and block style. Block style: riser is delivered loose.	

PACKING UNITS | WP QUADRA































UNIT	PACKAGE	PALLET
CONTENTS	6 boards = 1,63 m ²	60 packages = 97,80 m ²
DIMENSIONS	1,71 x 0,18 x 0,09 m	1,75 x 1,08 x 0,95 m
WEIGHT	approx. 10,65 kg	approx. 696 kg
EDGE PROFILE FOR STEPS	Fixed length: 1,70 m; profile 40, 40 style, 58 style and block style. Block style: riser is delivered loose.	

COLOUR RANGE OVERVIEW

STOCK ITEM

 <p>COLOR RANGE LAVA FUMED OAK lively (original*) ▪ WP Charisma Plank, WP Quadra</p>	 <p>COLOR RANGE TERRA OAK COGNAC rustic (essence) ▪ WP Charisma Plank</p>	 <p>COLOR RANGE TERRA NUT STEAMED lively colourful (original*) ▪ WP Quadra</p>	 <p>COLOR RANGE TERRA OAK COFFEE lively (original*) ▪ WP Charisma Plank</p>	 <p>COLOR RANGE TERRA OAK HAVANA rustic colourful (original) ▪ WP Comfort Plank</p>
 <p>COLOR RANGE TERRA OAK HAVANA lively colourful (spektrum) ▪ WP Charisma Plank</p>	 <p>COLOR RANGE NATUR OAK MANDEL rustic (astig) ▪ WP Charisma Plank</p>	 <p>COLOR RANGE NATUR OAK calm (select) ▪ WP Charisma Plank, WP Performance Plank, WP Comfort Plank, WP Quadra 1800</p>	 <p>COLOR RANGE NATUR OAK lively (akzent) ▪ WP Grand Plank, WP Quadra 1800, WP Charisma Plank, WP Performance Plank</p>	 <p>COLOR RANGE NATUR OAK rustic (original*) ▪ WP Comfort Plank</p>
 <p>COLOR RANGE NATUR OAK rustic (essence) ▪ WP Grand Plank, WP Quadra 1800, WP Charisma Plank</p>	 <p>COLOR RANGE NATUR OAK LIGHT rustic (essence) ▪ WP Charisma Plank</p>	 <p>COLOR RANGE NATUR OAK PURE lively (accent) ▪ WP Charisma Plank, WP Quadra 1800</p>	 <p>COLOR RANGE NATUR OAK PURE rustic (essence) ▪ WP Quadra 1800</p>	 <p>COLOR RANGE NATUR OAK PURE rustic colourful (original) ▪ WP Comfort Plank</p>
 <p>COLOR RANGE STONE OAK AUSTER lively (akzent) ▪ WP Quadra 1800</p>	 <p>COLOR RANGE STONE OAK AUSTER rustic (essence) ▪ WP Charisma Plank</p>	 <p>COLOR RANGE STONE OAK AUSTER rustic colourful (original) ▪ WP Comfort Plank</p>	 <p>COLOR RANGE STONE OAK COLORADO DIAMOND ICE lively colourful (spektrum) ▪ WP Charisma Plank</p>	 <p>COLOR RANGE STONE OAK COLORADO DIAMOND ICE rustic colourful (original) ▪ WP Comfort Plank</p>
 <p>COLOR RANGE STONE OAK KASCHMIR calm (select) ▪ WP Charisma Plank, WP Comfort Plank, WP Quadra 1800</p>	 <p>COLOR RANGE STONE OAK KASCHMIR lively (accent) ▪ WP Charisma Plank</p>	 <p>COLOR RANGE STONE OAK KASCHMIR lively colourful (spektrum) ▪ WP Charisma Plank, WP Quadra 1800</p>	 <p>COLOR RANGE STONE OAK KASCHMIR rustic (essence) ▪ WP Charisma Plank</p>	 <p>COLOR RANGE STONE OAK KASCHMIR rustic colourful (original) ▪ WP Comfort Plank</p>

*no sapwood

 <p>COLOR RANGE STONE OAK ICE lively (accent)</p> <ul style="list-style-type: none"> WP Charisma Plank  	 <p>COLOR RANGE STONE OAK ICE rustic (essence)</p> <ul style="list-style-type: none"> WP Charisma Plank  	 <p>COLOR RANGE STONE OAK SAVANNE calm (select)</p> <ul style="list-style-type: none"> WP Quadra 1800  	 <p>COLOR RANGE STONE OAK SAVANNE lively (accent)</p> <ul style="list-style-type: none"> WP Quadra 1800  	 <p>COLOR RANGE STONE OAK SAVANNE lively colourful (original)</p> <ul style="list-style-type: none"> WP Performance Plank  WP Performance Plank 
 <p>COLOR RANGE STONE OAK SAVANNE rustic (essence)</p> <ul style="list-style-type: none"> WP Charisma Plank  	 <p>COLOR RANGE STONE OAK SAVANNE rustic colourful (original)</p> <ul style="list-style-type: none"> WP Comfort Plank  	 <p>COLOR RANGE STONE ASH POLAR rustic colourful (vibrant)</p> <ul style="list-style-type: none"> WP Comfort Plank  	 <p>COLOR RANGE STONE OAK POLAR lively (accent)</p> <ul style="list-style-type: none"> WP Charisma Plank  	 <p>COLOR RANGE STONE OAK POLAR lively colourful (spectrum)</p> <ul style="list-style-type: none"> WP Charisma Plank 
 <p>COLOR RANGE STONE OAK TAUPE lively colourful (spectrum)</p> <ul style="list-style-type: none"> WP Charisma Plank  	 <p>COLOR RANGE STONE OAK TRÜFFELGRAU calm (select)</p> <ul style="list-style-type: none"> WP Charisma Plank  	 <p>COLOR RANGE STONE OAK TRÜFFELGRAU lively colourful (spectrum)</p> <ul style="list-style-type: none"> WP Charisma Plank  	 <p>COLOR RANGE SAND STONE PINE EDELWEISS rustic colourful (original)</p> <ul style="list-style-type: none"> WP Charisma Plank  	 <p>COLOR RANGE SAND ASH lively colourful (natural)</p> <ul style="list-style-type: none"> WP Charisma Plank 

*no sapwood



The grading overview serves as a rough orientation. To obtain a representative grading picture please see our official grading book or get info from our partner portal:
<https://partner.weitzer-parkett.com>

WIDEBOARD APPEARANCE

OFFERS SPACIOUSNESS

PROVIDES A ROOM WITH STYLE AND DISTINCTIVENESS, WORKS WELL IN ALL SURROUNDINGS. THE SPECIAL FORMAT BETWEEN PLANK AND BLOCK. ITS GENEROUS APPEARANCE MAKES IT PERFECTLY SUITED TO LARGE OR SMALL AREAS.



WP 4140
2-LAYER PARQUET



- Luxurious format with an extremely wide choice of wood species, finishes and surfaces
- Tongue and groove joint on four sides **(01)**
- Tailor-made and dimensionally stable header joint by utilizing top-quality plywood **(02)**
- Spruce supporting material with vertically arranged growth rings **(03)**
- Bevel on the longitudinal and header joints **(04)**
- Ideally suited to underfloor heating, thanks to ideal overall thickness

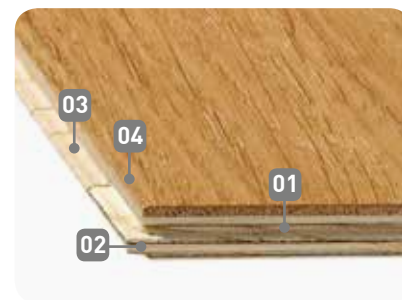

Herringbone* and French Herringbone* installation:

- All articles in all surfaces are suitable for Herringbone installation
 - Joint-edge impregnation is recommended
- For French Herringbone installation:
 - Inquiry possible for 60° and 45° laying
 - All items except **bevelled** in PS and PA+ suitable!
 - Joint-edge impregnation is recommended

* from an order of 20 m²



DIMENSIONS:

1400 x 140 x 11 mm
Overall thickness 11 mm with 3,6 mm wear layer



PACKING UNITS

UNIT	PACKAGE	PALLET
CONTENTS	10 boards = 1,96 m ²	56 packages = 109,76 m ²
DIMENSIONS	1,415 x 0,155 x 0,12 m	1,415 x 1,080 x 0,96 m
WEIGHT	approx. 12,29 kg	approx. 700 kg
EDGE PROFILE FOR STEPS	Fixed length: 1,40 m; profile 40, 40 style, 58 style and block style; Profile block style: riser is delivered loose.	

PACKING UNITS FRENCH HERRINGBONE

French Herringbone 45° = 1,76 m² per unit
French Herringbone 60° = 1,85 m² per unit

WP 4100

2-LAYER PARQUET



- Available in an extremely wide choice of wood species, finishes and surfaces
- Tongue and groove joint on four sides **(01)**
- Tailor-made and dimensionally stable header joint by utilizing top-quality plywood **(02)**
- Spruce supporting material with vertically arranged growth rings **(03)**
- Can be used in combination with WP 450



Herringbone* and French Herringbone* installation:

- All articles in all surfaces are suitable for Herringbone installation
 - Joint-edge impregnation is recommended
- For French Herringbone installation:
 - Inquiry possible for 60° and 45° laying
 - All items except **bevelled** in PS and PA+ suitable!
 - Joint-edge impregnation is recommended

* from an order of 20 m²

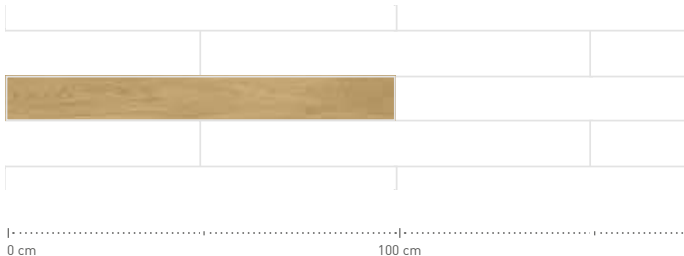

DIMENSIONS:

1000 x 125 x 11 mm

Overall thickness 11 mm with 3,6 mm wear layer

PACKING UNITS

UNIT	PACKAGE	PALLET
CONTENTS	12 boards = 1,50 m ²	64 packages = 96,00 m ²
DIMENSIONS	1,01 x 0,14 x 0,14 m	1,20 x 1,03 x 1,26 m
WEIGHT	approx. 9,20 kg	approx. 588,80 kg
EDGE PROFILE FOR STEPS	Fixed length: 1 m or 2 m; Profile 40, 40 style, 58 style and block style; Profile Block style: riser is delivered loose.	

PACKING UNITS FRENCH HERRINGBONE

French Herringbone 45° = 1,31 m² per unit

French Herringbone 60° = 1,38 m² per unit

WP CHARISMA 2-STRIP

3-LAYER PARQUET



- Intelligent patented double-click system with the greatest interlocking power on the market. **(01)**
- Patented press-stud principle for simultaneous locking of the longitudinal and header joints in one movement **(02)**:
 - Fast and simple one-man assembly and disassembly
 - Can be completely adhered to the subfloor*
- Header joint edge locking mechanism made from solid hardwood only - completely free from plastic components and plasticizers **(03)**
- Spruce supporting material with vertically arranged growth rings **(04)**
- HydroStop:
 - Unique all-round joint-edge impregnation
 - Provides the ultimate protection against the ingress of moisture due to small spillages
- **NOW NEW:** The WP rotatable plank allows a simple modification of the laying direction

* Ideally suited to underfloor heating, as it can be completely adhered to the subfloor

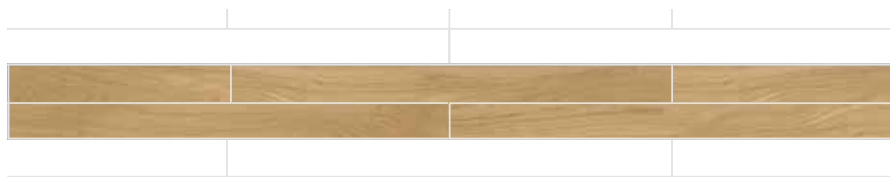

DIMENSIONS:

2245 x 193 x 14 mm

Overall thickness 14 mm with 3,6 mm wear layer





















PACKAGING UNIT

UNIT	PACKAGE	PALLET
CONTENTS	6 boards = 2,60 m ²	35 packages = 91,00 m ²
DIMENSIONS	2,28 x 0,215 x 0,085 m	2,28 x 1,10 x 0,71 m
WEIGHT	approx. 19,80 kg	approx. 693 kg
EDGE PROFILE FOR STEPS	Fixed length: 2,245 m; Profile 40, 40 style, 58 style and block style; Profile block style: riser is delivered loose.	

COLOUR RANGE OVERVIEW

STOCK ITEM

 <p>COLOUR RANGE LAVA FUMED OAK ICE lively (original*)</p> <ul style="list-style-type: none"> WP Charisma 2-Strip 	 <p>COLOUR RANGE LAVA FUMED OAK lively (original*)</p> <ul style="list-style-type: none"> WP 4100 	 <p>COLOUR RANGE TERRA OAK COFFEE lively (original*)</p> <ul style="list-style-type: none"> WP 4100 	 <p>COLOUR RANGE TERRA NUT STEAMED lively colourful (structure)</p> <ul style="list-style-type: none"> WP Charisma 2-Strip WP 4100 	 <p>COLOUR RANGE FIRE ROBINIA STEAMED lively colourful (original)</p> <ul style="list-style-type: none"> WP 4100
 <p>COLOUR RANGE NATUR OAK calm (select)</p> <ul style="list-style-type: none"> WP 4140, WP 4100 	 <p>COLOUR RANGE NATUR OAK lively (original*)</p> <ul style="list-style-type: none"> WP Charisma 2-Strip 	 <p>COLOUR RANGE NATUR OAK lively (accent)</p> <ul style="list-style-type: none"> WP 4140 WP 4100 	 <p>COLOUR RANGE NATUR OAK PURE calm (select)</p> <ul style="list-style-type: none"> WP 4140 	 <p>COLOUR RANGE STONE OAK AUSTER calm (select)</p> <ul style="list-style-type: none"> WP 4140
 <p>COLOUR RANGE STONE OAK COLORADO DIAMOND ICE lively colourful (spectrum)</p> <ul style="list-style-type: none"> WP 4100 	 <p>COLOUR RANGE STONE OAK KASCHMIR calm (nature)</p> <ul style="list-style-type: none"> WP 4140, WP 4100 	 <p>COLOUR RANGE STONE OAK KASCHMIR lively (accent)</p> <ul style="list-style-type: none"> WP 4140 WP Charisma 2-Strip 	 <p>COLOUR RANGE STONE OAK KASCHMIR lively colourful (spectrum)</p> <ul style="list-style-type: none"> WP 4100 	 <p>COLOUR RANGE STONE OAK ICE lively (original*)</p> <ul style="list-style-type: none"> WP 4140
 <p>COLOUR RANGE STONE OAK SAVANNE calm (select)</p> <ul style="list-style-type: none"> WP 4140 	 <p>COLOUR RANGE STONE ASH POLAR lively colourful (natural)</p> <ul style="list-style-type: none"> WP Charisma 2-Strip 			



 The grading overview serves as a rough orientation. To obtain a representative grading picture please see our official grading book or get info from our partner portal: <https://partner.weitzer-parkett.com>

*no sapwood



BLOCK APPEARANCE

CREATES MORE LATITUDE

A PARQUET THAT MATCHES ANY STYLE: THE BLOCK APPEARANCE IS A TIMELESS CLASSICAL DESIGN. THANKS TO ITS DIVERSITY, BLOCK PARQUET GOES WELL WITH ANY STYLE OF FURNISHING.



BLOCK APPEARANCE | FUMED OAK | LIVELY (ORIGINAL*)

*no sapwood

WP 450
2-LAYER PARQUET



- Available in an extremely wide choice of wood species, finishes and surfaces
- Tongue and groove joint on four sides **(01)**
- Tailor-made and dimensionally stable header joint by utilizing top-quality plywood **(02)**
- Spruce supporting material with vertically arranged growth rings **(03)**
- Offers the greatest freedom of choice of installation patterns, also perfect for combining with WP 4100

Herringbone and French Herringbone* installation:

- All articles in all surfaces are suitable for Herringbone installation
 - Joint-edge impregnation is recommended
- For French Herringbone installation:
 - Inquiry possible for 60° and 45° laying
 - Joint-edge impregnation is recommended



* from an order of 20 m²



DIMENSIONS:
500 x 65 x 11 mm
Overall thickness 11 mm with 3,6 mm wear layer

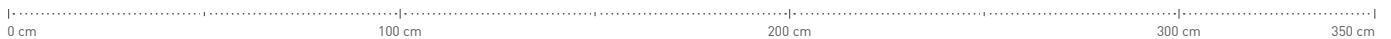

PACKING UNITS

UNIT	PACKAGE	PALLET
CONTENTS	72 boards = 2,34 m ² <small>(each package contains 50% right and 50% left blocks)</small>	30 packages = 70,20 m ²
DIMENSIONS	0,51 x 0,28 x 0,205 m	1,20 x 0,80 x 1,18 m
WEIGHT	approx. 14,29 kg	approx. 428,70 kg
EDGE PROFILE FOR STEPS	Fixed length: 1 m, 1,5 m or 2 m; Profile 40, 40 style, 58 style and Block style; Profile Block style: riser is delivered loose	

PACKING UNITS FRENCH HERRINGBONE

French Herringbone 45° = 2,04 m² per unit
French Herringbone 60° = 2,15 m² per unit

WP CHARISMA 3-STRIP 3-LAYER PARQUET



- Intelligent patented double-click system with the greatest interlocking power on the market. **(01)**
- Patented press-stud principle for simultaneous locking of the longitudinal and header joints in one movement **(02)**:
 - Fast and simple one-man assembly and disassembly
 - Can be completely adhered to the subfloor*
- Header joint edge locking mechanism made from solid hardwood only - completely free from plastic components and plasticizers **(03)**
- Spruce supporting material with vertically arranged growth rings **(04)**
- HydroStop:
 - Unique all-round joint-edge impregnation
 - Provides the ultimate protection against the ingress of moisture due to small spillages
- **NEW NEW:** The WP rotatable plank allows a simple modification of the laying direction



* Ideally suited to underfloor heating, as it can be completely adhered to the subfloor

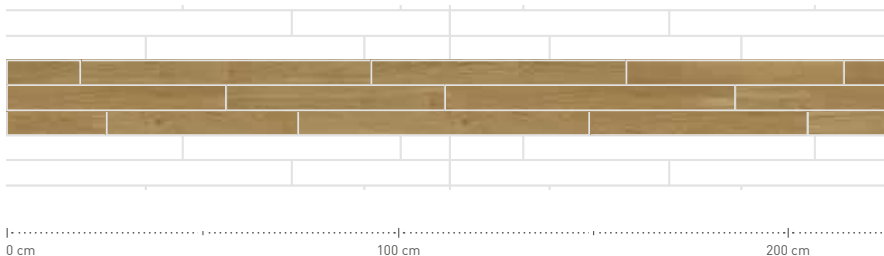

























DIMENSIONS:
2245 x 193 x 14 mm
Overall thickness 14 mm with 3,6 mm wear layer

PACKING UNITS

UNIT	PACKAGE	PALLET
CONTENTS	6 boards = 2,60 m ²	35 packages = 91,00 m ²
DIMENSIONS	2,28 x 0,215 x 0,085 m	2,28 x 1,10 x 0,71 m
WEIGHT	approx. 19,80 kg	approx. 693 kg
EDGE PROFILE FOR STEPS	Fixed length: 2,245 m; Profile 40, 40 style, 58 style and Block style; Profile Block style: riser is delivered loose	

COLOUR RANGE OVERVIEW

STOCK ITEM

 <p>COLOUR RANGE LAVA FUMED OAK lively (original*) ▪ WP 450, WP Charisma 3-Strip</p>	 <p>COLOUR RANGE TERRA NUT STEAMED lively colourful (original) ▪ WP 450, WP Charisma 3-Strip</p>	 <p>COLOUR RANGE TERRA OAK COFFEE lively (original*) ▪ WP 450</p>	 <p>COLOUR RANGE TERRA OAK HAVANA lively colourful (structure) ▪ WP Charisma 3-Strip</p>	 <p>COLOUR RANGE FIRE ROBINIA STEAMED lively colourful (original) ▪ WP 450, WP Charisma 3-Strip</p>
 <p>COLOUR RANGE FIRE CHERRY STEAMED lively colourful (original) ▪ WP Charisma 3-Strip</p>	 <p>COLOUR RANGE FIRE BEECH STEAMED calm (nature) ▪ WP 450, WP Charisma 3-Strip</p>	 <p>COLOUR RANGE FIRE BEECH STEAMED lively colourful (structure) ▪ WP Charisma 3-Strip</p>	 <p>COLOUR RANGE NATURE OAK exquisit (exquisite) ▪ WP 450 WP Charisma 3-Strip</p>	 <p>COLOUR RANGE NATURE OAK calm (nature) ▪ WP 450 WP Charisma 3-Strip</p>
 <p>COLOUR RANGE NATURE OAK lively (accent) ▪ WP 450</p>	 <p>COLOUR RANGE NATURE OAK lively colourful (structure) ▪ WP Charisma 3-Strip</p>	 <p>COLOUR RANGE NATURE OAK lively colourful (spectrum) ▪ WP 450</p>	 <p>COLOUR RANGE NATURE OAK PURE calm (nature) ▪ WP Charisma 3-Strip</p>	 <p>COLOUR RANGE STONE OAK AUSTER calm (nature) ▪ WP 450, WP Charisma 3-Strip</p>
 <p>COLOUR RANGE STONE OAK KASCHMIR calm (nature) ▪ WP 450, WP Charisma 3-Strip</p>	 <p>COLOUR RANGE STONE OAK KASCHMIR lively colourful (spectrum) ▪ WP 450</p>	 <p>COLOUR RANGE STONE OAK SAVANNE calm (nature) ▪ WP 450, WP Charisma 3-Strip</p>	 <p>COLOUR RANGE STONE ASH POLAR calm (select) ▪ WP Charisma 3-Strip</p>	 <p>COLOUR RANGE SAND ASH LATTE calm (select) ▪ WP 450</p>
 <p>COLOUR RANGE SAND CANADIAN MAPLE calm (nature) ▪ WP 450, WP Charisma 3-Strip</p>	 <p>COLOUR RANGE SAND CANADIAN MAPLE lively colourful (structure) ▪ WP 450, WP Charisma 3-Strip</p>	 <p>COLOUR RANGE SAND ASH calm (select) ▪ WP 450, WP Charisma 3-Strip</p>	 <p>COLOUR RANGE SAND ASH lively colourful (structure) ▪ WP 450, WP Charisma 3-Strip</p>	 <p>The grading overview serves as a rough orientation. To obtain a representative grading picture please see our official grading book or get info from our partner portal: https://partner.weitzer-parkett.com</p>

STRIP APPEARANCE

STANDS FOR DESIGN

MODERN AND MULTIFACETED,
STRIP PARQUET WITH ITS
NUANCED STRIPS CREATES
IMPARTING SPECIAL ACCENTS
IN YOUR ROOMS.



WP STRIP 45
2-LAYER-PARQUET



- Unusually effective design - exclusively from Weitzer Parkett
- Extremely high-grade and long-lasting due to above-average solid wood wear layer of approx. 4.5 mm
- Tongue and groove joints on four sides **(01)**
- Supporting material made from moisture resistant HDF **(02)**
- Unbeatable price/performance ratio

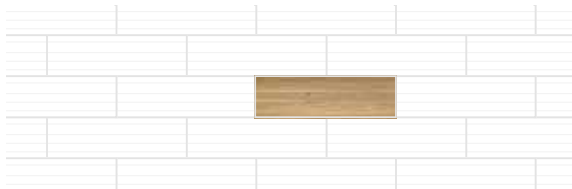

DIMENSIONS:
360 x 108 x 11 mm
Overall thickness 11 mm with 4,5 mm wear layer

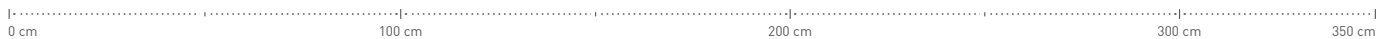









PACKING UNITS

UNIT	PACKAGE	PALLET
CONTENTS	36 boards = 1,40 m ² <small>(each package contains 50% right and 50% left blocks)</small>	50 packages = 70 m ²
DIMENSIONS	0,37 x 0,23 x 0,21 m	1,20 x 0,80 x 1,20 m
WEIGHT	approx. 12,7 kg	approx. 635 kg
EDGE PROFILE FOR STEPS	Fixed length: 1,08 m, 1,44 m, 1,80 m or 2,16 m; Profile 40, 40 style, 58 style and Block style; Profile Block style: riser is delivered loose	



COLOUR RANGE OVERVIEW

STOCK ITEM

 <p>COLOUR RANGE LAVA FUMED OAK calm (nature)</p> <ul style="list-style-type: none"> WP Strip 45 	 <p>COLOUR RANGE TERRA NUT STEAMED lively colourful (original)</p> <ul style="list-style-type: none"> WP Strip 45 	 <p>COLOUR RANGE FIRE ROBINIA STEAMED lively colourful (original)</p> <ul style="list-style-type: none"> WP Strip 45 	 <p>COLOUR RANGE NATURE OAK calm (nature)</p> <ul style="list-style-type: none"> WP Strip 45 	 <p>COLOUR RANGE NATURE OAK lively colourful (structure)</p> <ul style="list-style-type: none"> WP Strip 45
 <p>COLOUR RANGE STONE OAK KASCHMIR calm (nature)</p> <ul style="list-style-type: none"> WP Strip 45 	 <p>COLOUR RANGE SAND ASH calm (select)</p> <ul style="list-style-type: none"> WP Strip 45 	 <p>COLOUR RANGE SAND ASH lively colourful (natural)</p> <ul style="list-style-type: none"> WP Strip 45 		



The grading overview serves as a rough orientation. To obtain a representative grading picture please see our official grading book or get info from our partner portal:
<https://partner.weitzer-parkett.com>

WOODEN STAIRS WP MULTI

PARQUET AND
STAIRS IN IDENTICAL
COLOURS

THE PERFECT FINISH
TO YOUR INTERIOR.



06
LOOSE EDGE
PROFILE FOR STEPS
(LEP)



Quick and flexible solution
on site! Fixed length: 2500 mm
(including tongue with Imperial Plank, WP Charisma,
WP Comfort Plank and WP Strip 45)

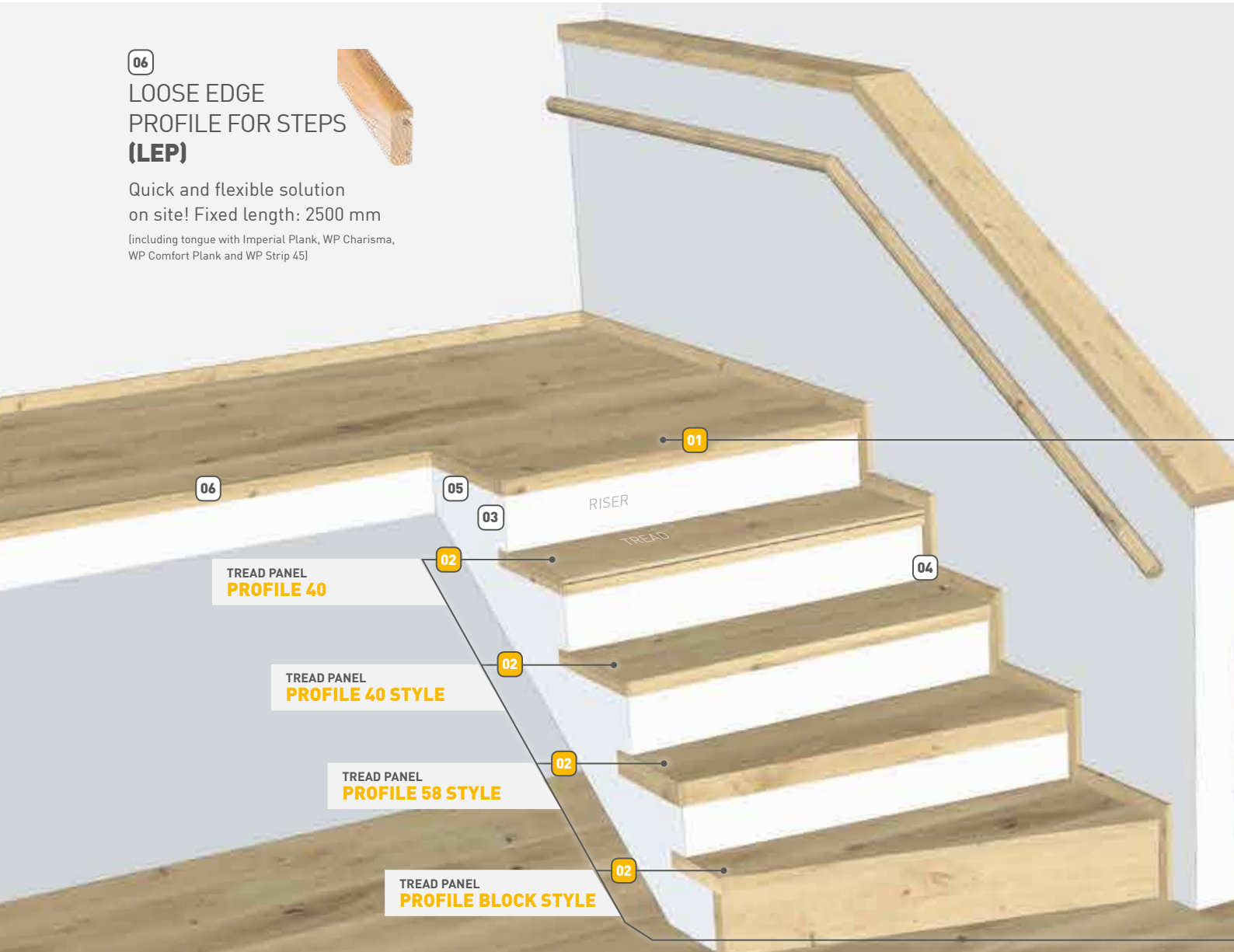

06

TREAD PANEL
PROFILE 40

05

03

RISER

01

TREAD

04

TREAD PANEL
PROFILE 40 STYLE

02

TREAD PANEL
PROFILE 58 STYLE

02

TREAD PANEL
PROFILE BLOCK STYLE

02

03 MULTI FRONT EDGE - RISER (FER)

Covers the side of the risers (vertically) and rounds off the overall picture of the staircase. It is available in white (see image) or in all parquet appearances.

04 MULTI WALL COVER MOULDING (WCM)

The final touch for wall clearance. Offers protection against abrasion and dirt.

05 MULTI FRONT EDGE (FE)

The Multi Front Edge covers the open sides of the tread. The Multi Front Edge is provided with a permanent tongue. A router and a 4 mm groove cutter with thrust ring are needed for installation.

Precise,
stable
fixation of
Front Edge
(FE)*



Also available **without** tongue!

PROFILE 40:

Dimensions: 350 x 40/58 x 6 mm | Dimensions: 600 x 40/58 x 6 mm

* Grooves must be cut during installation

03 + 04 + 05 WP MULTI MOULDING SYSTEM

The intelligent moulding system made of genuine wood for all applications—whether straight, L- or U-shaped, or slanting. Consisting of **Multi Front Edge (FE)**, **Multi Front Edge - Riser (FER)**, and the **Wall Cover Moulding (WCM)**, they fit every Weitzer parquet and every multi-stair variation. **Available in every wood species and colour of the Weitzer Parkett assortment.**

WEITZER PARKETT OFFERS MATCHING STAIRS FOR EVERY PARQUET FLOOR - IRRESPECTIVE OF WHICH TIMBER OR COLOUR TONE YOU USE - CREATING COLOUR CONSISTENCY THROUGHOUT



01 EDGE PROFILE FOR STEPS (EP)

The stair-edge profile consists of a multi-moulding and a parquet strip (profile 40). The profile for the 40 style, 58 style and block style variants is crafted from a single piece of parquet. The stair-edge profile is the termination of each stair (exit) and allows the adjacent parquet to continue to be laid seamlessly. (continued frontal laying on request)

Immediately click on For example continue installation



PROFILE 40
40 mm edge band



PROFILE 40 STYLE
40 mm



PROFILE 58 STYLE
58 mm



PROFILE BLOCK STYLE
Variable riser*

* Height depends on each product. SYMBOLIC PHOTOS

02 TREAD PANEL

Consists of several parquet strips (number of parquet strips varies depending on parquet appearance) and terminates at the longitudinal sides each with multi-moulding.

AVAILABLE MODELS:

Profile 40, 40 style, 58 style and Block style profile

You'll find a detailed description of the individual profiles on the next page.



Standard 17 mm thick carrier panel, 6 mm or 27 mm thickness deliverable on request

Two treads can be produced per large die plate.

TREAD COMBINATION

Exemplary presentation of the tread combination for each cut is displayed on the back side. However this serves only as guidance. Exact measures must always be taken on site!



PLANK APPEARANCE*



WIDEBOARD APPEARANCE

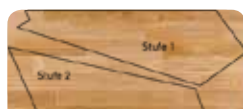

BLOCK APPEARANCE

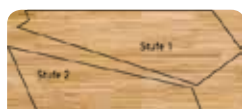

STRIP APPEARANCE „CLASSIC“ installation

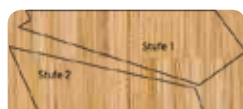

STRIP APPEARANCE „DESIGN“ installation

* Continuous top layer (no header joint) is possible at an extra cost.

THE TREAD PANEL IN DETAIL

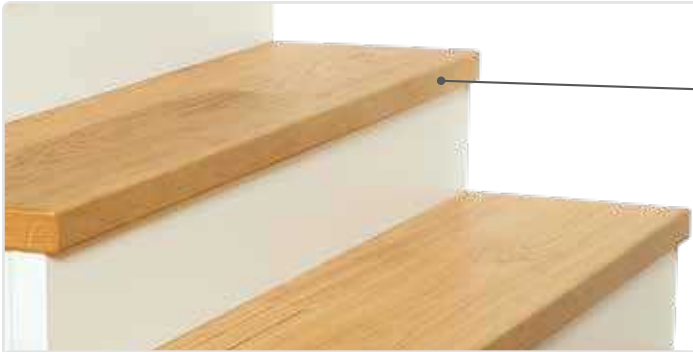

Consists of several parquet strips* and connects each longitudinal side with a multi-moulding. **Two treads** can be produced per tread panel. Edge radius: 5 mm

TREAD PANEL **PROFILE 40**



Consists of several parquet strips and terminates with a mitred parquet surface on each of the longitudinal sides. Two step treads can be produced per large-format tread. Edge radius: 3 mm

TREAD PANEL **PROFILE 40 STYLE**



Consists of several parquet strips and terminates with a mitred parquet surface on each of the longitudinal sides. Two step treads can be produced per large-format tread. Edge radius: 3 mm

TREAD PANEL **PROFILE 58 STYLE**



Perfect joining technology!
Joining the riser and tread without shadow gap.
Edge radius: 3 mm

TREAD PANEL **PROFILE BLOCK STYLE**

* Number of parquet strips varies depending on parquet appearance.

** Height depends on each product.

PROFESSIONAL INSTALLATION WITH SCREW CONNECTED RISER

FOR A PERFECT RESULT

OPTIMIZED INSTALLATION CONDITIONS
OF THE RISER USING AN EXACT
EDGE AND PRE-DRILLED
THREADED-CONNECTION HOLES.



YOUR BENEFITS AT A GLANCE:

- Prefabricated riser as an ideal solution to cover existing structure **(01)**
(Brickworks/Painting not necessary)
- Pre-drilled, countersunk threaded connection in the riser **(02)**
(simple one-man installation)
- Remarkable saving of installation time

FORCE-FIT CONNECTION

of the riser
with the tread

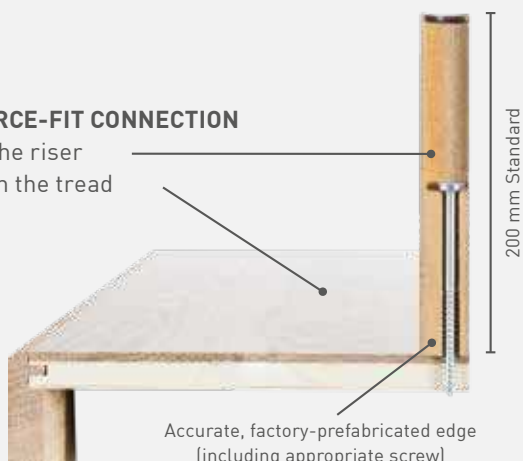

WP MULTI POSSIBILITIES

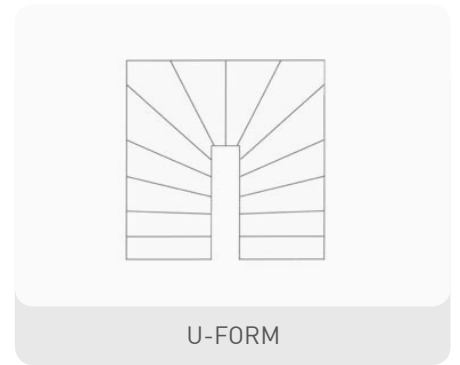
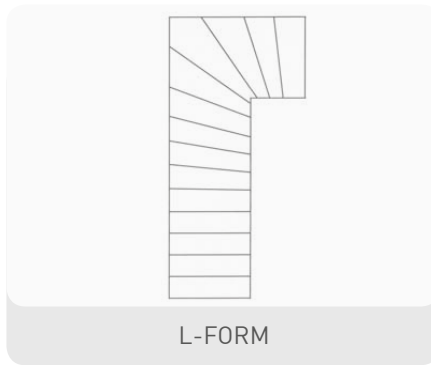
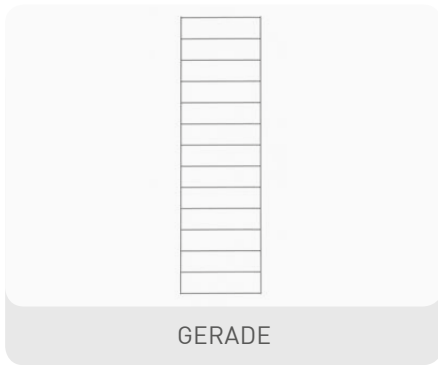

SOLID HAND RAILS



** 5 mm edge radius



PARQUET MOULDING SYSTEM

FROM SIMPLE TO ELEGANT

INTELLIGENT AND PROVEN
SOLUTIONS FOR THE
PERFECT FINISH
OF YOUR INTERIOR.

PARQUET SKIRTINGS

A MATCHING
SKIRTING FOR
EVERY FLOOR.

VENEERED SKIRTINGS





VENEERED SKIRTINGS



SOLID SKIRTINGS





PARQUET ACCESSORIES

**FOR A LONG
PARQUET LIFE!**

WITH THE RIGHT ACCESSORIES,
THE PARQUET STAYS BEAUTIFUL
YEARS AFTER ITS INSTALLATION



GUARANTEED FREE FROM PLASTICIZERS

WEITZER PARKETT
SETS STANDARDS:
WITH A UNIQUE OVERALL
SOLUTION FREE FROM
PLASTICIZERS!

ENVIRONMENTALLY
FRIENDLY

We are the first and only provider on the market to offer you an overall solution free from plasticizers: from the parquet floor to the adhesive. Another contribution to improved health and the preservation of Mother Nature.

Weitzer Parkett is well aware of its environmental responsibility and implements this throughout the entire value-added chain - from the procurement of raw materials right up to our wood waste recycling. In the same manner, we place great emphasis on using environmentally safe products required in the production of our parquet flooring.

PROFI SMP ADHESIVE NO. 950



PRODUCT DETAILS

- 1-component, label-free adhesive
- Use with 2- and 3-layer parquet:
1000 g/m² to 1200 g/m²
- Application: suitable for complete adhesion of solid wood floors, 2-layer and 3-layer parquet*

YOUR BENEFITS AT A GLANCE:

- free from Plasticizers
- does not contain potentially migrating components after curing
- free from solvents and water
- Sustainability: Parquet that has been removed after a long period of use can in future be fed into the recycling execute at significantly lower cost. Thanks to the environmentally friendly adhesive, no harmful substances can be absorbed by the wood, which means that it can be fully recycled for future use.

Easy-to-execute, exemplary solution –in terms of the environment and economics

WEITZER PARKETT FIDBOX®

SAFETY
INCLUDED.

The fidbox® is a climate monitor that is hidden in the parquet for measuring the temperature (°C) and relative humidity (%), and a data logger for ongoing data recording all in one. The data stored in the device can be read at any time and allows for determination of the temperature as well as the level of humidity of the screed/subfloor and wood. Not only is this information of interest when it comes to room climate, it also provides clear evidence in the event of damage.

YOUR BENEFITS AT A GLANCE:

- The fidbox® has already been used on numerous occasions to indemnify parquet installers in cases of claims against them. The device measures the temperature and relative humidity and consequently provides recognised data that can be verified by experts.
- The **fidbox®** is integrated in the parquet floor. The stored data can be easily read out at a later stage by using a specific **APP**.
- The **fidbox® APP** enables end customers, builders, or the building supervision company to constantly monitor indoor climatic conditions remotely (via Bluetooth). This also applies in particular to residences that have stood empty for a long time.



Installing a fidbox® is mandatory for the WP Grand plank. This enables you to seek specialist advice and optimize your indoor climate even after the parquet has been laid, thereby ensuring the value of the parquet floor is preserved. This will ensure your clients can look forward to a long and happy life together with their parquet floor.



WOOD - AT ITS BEST

FROM MAPLE TO STONE PINE

THE DIFFERENT WOOD SPECIES WE USE SERVE TO REFLECT THE INFINITE DIVERSITY OF NATURE.

WOOD - AT ITS BEST

OUR WOOD SPECIES MIRROR MOTHER NATURE'S DIVERSITY.



OAK - THE STEADFAST ONE

BOTANICAL NAME QUERCUS

The highly characteristic, long-living oak is amongst the most valuable of domestic timbers. The timeless classic stands for robustness - the wood of this dependable tree is durable, hard, firm and elastic all in one. This makes it the perfect wood for a wide range of additional colour treatments, because it works with all furniture styles and is perfect for use with underfloor heating, oak remains the wood of choice for most people selecting a parquet floor.

Origin: primarily Austria, Hungary and Croatia.



BEECH - THE FLEXIBLE ONE

BOTANICAL NAME FAGUS SYLVATICA

The beech is Austria's most common deciduous tree, and is often affectionately referred to as the "mother of the forest" as a result. The hard, durable wood, with its fine, discreet growth pattern, is easy to steam bend, after which it retains its new shape. The diverse range of styles to which beech lends itself, from rustic to elegant, make it the wood most used in parquet after oak. Beech wood is distinctive for its light yellow to pinky-brown colouring.

Origin: Austria, Hungary and Slovakia.

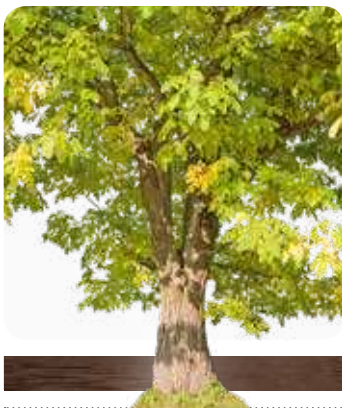

WALNUT - THE PRECIOUS ONE

BOTANICAL NAME JUGLANS NIGRA

One of the most valuable and sought-after timbers, walnut has been viewed for centuries now as one of the most precious wood species for the production not just of parquet flooring and furniture, but also of musical instruments. Thanks to its colouring, which ranges from matt to blackish-brown, and its marking, this attractive wood gives any room it graces a particularly luxurious ambience. Its varied appearance makes it the ideal choice for those wishing to create effective contrasts.

Origin: Central and Eastern Europe, USA



ACACIA- THE ROBUST ONE

BOTANICAL NAME ROBINIA PSEUDOACACIA

The wood of the perennial acacia has a wide range of different uses: it is one of the heaviest and hardest domestic wood species, and has a high level of resistance. One special characteristic of acacia wood is its resistance to weathering, while it is also highly stable and flexible. Visually, the acacia's distinct structuring and warm, reddish-brown colouring, which is brought out by means of a steam execute, is highly pleasing.

Origin: Hungary



WOOD - AT ITS BEST

OUR WOOD SPECIES MIRROR MOTHER NATURE'S DIVERSITY.



ASH - THE VITAL ONE BOTANICAL NAME FRAXINUS EXCELSIOR

Thanks to the high quality of its wood, the ash is one of the most precious deciduous woods, and together with beech and oak, one of the most important timbers in Central Europe. The expressive, distinctively structured wood, with its pronounced annual rings, is harder, tougher and more flexible than that of many other trees. For that reason, ash wood is most popular amongst those with the highest requirements when it comes to toughness and flexibility. Thanks to its special marking with a brown core, the ash is often known as the 'core ash'.

Origin: Austria, Hungary, Croatia and Ukraine.

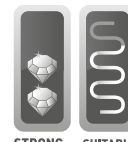

CANADIAN MAPLE - THE CHARMING ONE BOTANICAL NAME ACER SACCHARUM

Canadian maple is both harder and more distinctive in its graining than the mountain maple. The sugar maple, as this wood is also known due to the famous maple sugar which can be produced from the sap of the tree, is one of the most valuable of the maple species. With its eyed texture and the warm appearance of its wood, the Canadian Maple is popular amongst those wishing to combine it with other woods, and has a wide range of uses compared to other light wood species due to its hardness.

Origin: Canada and North-Eastern USA

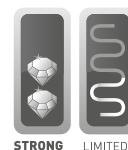

CHERRY - THE WARMING ONE BOTANICAL NAME PRUNUS AVIUM

Cherry continues to be a classic in the furniture world, and was the most popular wood of the Biedermeier and art nouveau era. Again and again, this refined precious wood motivated designers of the time to create elegant, beautifully shaped - and of course, comfortable - furniture. Its reddish-gold brown colour gives any room a warm, comfortable radiance. The lively, natural graining makes it particularly decorative, and the perfect wood to use in contrast with white or darker woods.

Origin: primarily Austria and Croatia.

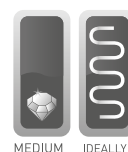

STONE PINE - THE AROMATIC ONE BOTANICAL NAME PINUS CEMBRA

The stone pine is one of the few domestic wood species which, as well as its striking graining (numerous dark-brown knots), has an unmistakable scented aroma which hangs strongly in the air. The essential oils contained in pinewood have been proven to have a positive effect on our health and wellbeing. According to a survey by Joanneum Research Austria, pinewood reduces the heart rate and promotes regeneration in the body. Stone Pine also has a positive influence on our sensitivity to weather conditions. In addition to this, pinewood has a high antibacterial effect, and even serves as an effective protection against insects thanks to the special substances contained in it. As a result, the stone pine is primarily used in bedrooms and wellness areas.

Origin: selected mountain regions in Austria.

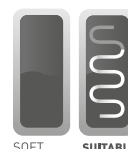

NO SOONER SAID THAN DONE.

We listen to Mother Nature, and feel obliged to align our company with the environment. We invite you to follow our example!

- Our raw timber is almost exclusively derived from European, sustainable forests.
- We are the first parquet manufacturer to have ceased using tropical hardwood timber for a number of years.
- Support for Greenpeace forest projects. By purchasing a Weitzer Parkett product, you are contributing to saving the last remaining virgin forests in Romania.
- Energy is a valuable resource, our internal biomass power plant, photovoltaic systems and hydroelectric power plant allow us to produce not only environmentally friendly district heating, but also eco-power. The energy produced in this sustainable manner provides power not only for Weitzer Parkett but also for more than half of the city of Weiz. This corresponds to a capacity of more than 2000 households.
- We make a significant contribution to a positive eco balance by means of our overall value-add chain: resources from nearby locations, short transport paths, production in Austria, renewable energy, and much more besides.
- **We are a step ahead: Weitzer Parkett is the first and only manufacturer in the market to offer an overall solution for parquet flooring and adhesive that is free from plasticizers.**

THIS IS PARQUET INTELLIGENCE:

HAND IN HAND WITH MOTHER NATURE

Do you expect Environmental Responsibility that you can trust?

Our Intelligent Solution: Tropical timber has been a taboo for us for a long time and we actively support Greenpeace's forest protection projects. Our innovative strength helps us to implement particularly efficient measures in matters of ecology: our in-house biomass co-generation plant, photovoltaic system, and hydroelectric plant are just a few examples of our responsible actions in terms of future generations.



WE LISTEN TO MOTHER NATURE

OUR ECOLOGICAL
RESPONSIBILITY
FOR FUTURE
GENERATIONS.



**70 m² WP Charisma
Oak planks bind
1 ton of CO₂**

„Healthy flourishing forests play a key role in the global climate, and consequently for life as a whole. Accepting responsibility for the environment is a major concern for us. That’s why as personal sponsors, we support the **GREENPEACE** forest campaign in Romania for the preservation of the last remaining virgin forests in Europe“

**Dr. Nicola Weitzer
Mag. Alexandra Decker-Weitzer**



ENVIRONMENTAL RESPONSIBILITY

OUR CERTIFICATIONS PROVE OUR LIVED ENVIRONMENTAL PROTECTION AND SUSTAINABILITY

*FSC/PEFC: product certification available upon request.

FSC®:
WE ARE
CERTIFIED.



The mark of responsible forestry

FSC® (Forest Stewardship Council®) confers its certificates only on those companies using woods for their products that have been felled without exploiting natural, economic, or social resources.

SUSTAINABILITY
IS EFFECTIVE!



The Environmental Product Declaration (EPD), verified by an independent institute for construction and housing, the Institut für Bauen und Wohnen, makes us the first parquet manufacturer to provide detailed information on the life-cycle environmental impact of our products!

WE'RE TAKING
RESPONSIBILITY.



Weitzer Parkett holds the PEFC Certificate of sustainable forestry. This Europe-wide system of forest certification acts as a common framework for national and regional certification schemes PEFC (Programme for the Endorsement of Forest Certification scheme) is a certification system initiated by European private forest owners and promotes sustainable forestry.

WE STAND FOR
REAL VALUES.



Developed by the European Federation of the Parquet Industry ("FEP"), only solid and multi-layered real wood floors such as those manufactured by Weitzer Parkett may carry the Real Wood logo. The campaign for real wood floors has been developed to avoid confusion between real timber floors and laminate floors (laminate cannot carry the "Real Wood" label).

ENVIRONMENTAL
PROTECTION: WE'RE
TAKING A STANCE.



As the world's oldest and best-known eco-label, the Blue Angel stands for credibility and competence. It identifies products which are particularly environmentally friendly and at the same time meet high demands in relation to health and employment protection. Weitzer Parkett products have been tested in accordance with these strict guidelines, and as a result are entitled to carry the Blue Angel seal of approval.

YOUR TRUST
IS IMPORTANT
TO US.



The GREENGUARD certificate guarantees no harmful chemical emissions of our 3-layer floors.

WE LET YOU
BREATH EASILY.



The TÜV PROFiCERT product Interior is an independent quality symbol for interior products with regard to emissions. Under this voluntary, external monitoring scheme, the emissions of our products are tested and assessed according to the most stringent criteria. In this way we verify that: Weitzer Parkett ensures a good interior air quality in your rooms.



Weitzer Parkett GmbH & CoKG
Klammstrasse 24
8160 Weiz, AUSTRIA
Tel.+43 (0)3172/2372-0
Fax +43 (0)3172/2372-401
office@weitzer-parkett.com

